

THE MERTON GROUP

Municipal Broadband Network

Engineering Study¹

TOWN OF BELMONT, MA

April 2003

DRAFT

By

The Merton Group, LLC

¹ © The Merton Group, LLC, 2003, all rights reserved. Not to be reproduced without the express written authorization of Merton. Licensed to the Town of Belmont for internal use only.

Contents

- 1. Executive Summary3
 - 1.1 Objectives3
 - 1.2 Design Process3
- 2. Network Layout.....5
 - 2.1 Design Constraints.....5
 - 2.2 Design Inputs.....5
 - 2.3 Design Performance Issues.....7
 - 2.4 Design Methodology.....7
- 3. Analysis of Plant Build.....8
 - 3.1 Methodology8
 - 3.1.1 Headend.....8
 - 3.1.2 Network Elements.....8
 - 3.1.3 Sectorizing.....9
 - 3.1.4 Network Layout.....9
 - 3.2 Results..... 11
 - 3.2.1 Sector Design..... 11
 - 3.2.2 Basic Network Build Data Analysis 12
 - 3.2.3 Setback..... 13
 - 3.2.4 Make Ready 13
 - 3.2.5 Aerial..... 14
- 4. System Design..... 15
 - 4.1 System Elements 15
 - 4.2 Key Definitions 15
 - 4.3 Passive Optical Networking 16
 - 4.4 Gigabit Ethernet 19
 - 4.5 PON/ATM vs. Gigabit Ethernet20
- 5. Capital Plant Estimates21
 - 5.1 Cost Models21
 - 5.2 Fiber Network Costs21
 - 5.3 Electronic Costs21
 - 5.3.1 PON Cost Elements21
 - 5.3.2 GigE Cost Elements22
 - 5.4 Cost per HH.....23
 - 5.4.1 PON CAPEX.....23
 - 5.4.2 GigE CAPEX.....23
- 6. Field Data.....25
- 7. Detailed Field Photos.....27

1. EXECUTIVE SUMMARY

This report is a preliminary engineering analysis of the plant build for Belmont, MA. It is based upon a analysis of the town based upon direct analysis of the network size, demand, layout for coverage, and performance. The analysis is also based upon detailed field measurements which are contained in detail herein. The analysis is NOT the final analysis of the cost to build, it is a Preliminary analysis based upon the field engineering data. The main purpose of this report is to provide a review mechanism for the overall plan.

1.1 Objectives

This report will be used as a part of the overall Feasibility Study to be undertake by Merton. The objectives of this report are as follows:

1. Establish the key design factors for the deployment of the MBN.
2. Determine the detailed design elements and do so in a fashion which uses actual field measurements.
3. Develop a baseline network build plan for the town.
4. Perform a detailed analysis of the town and the elements which will be part of the build plan. This includes the development of a data base of images of the key deployment elements, including; pole make ready issues, percent aerial, set back distances per HH, and frontage per HH.
5. Use the detailed results to develop as preliminary design.
6. Using the preliminary design, develop a capital estimating model for the network

These elements have been accomplished and are contained herein.

1.2 Design Process

The actual process used in the development of the engineering analysis is shown in the following graphic which is further detailed in this report.

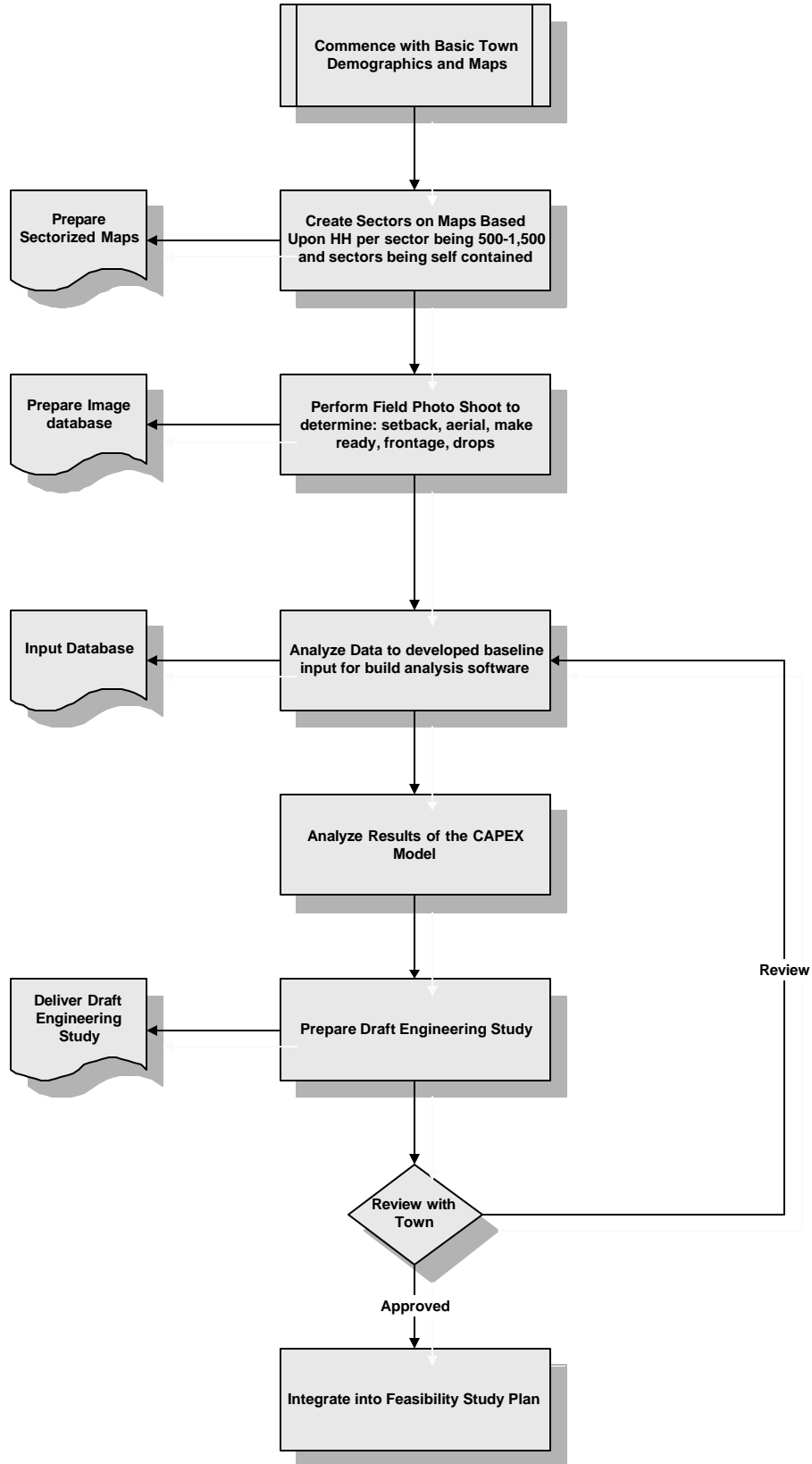

2. NETWORK LAYOUT

The network layout is based upon the constraints, performance, and also to some degree upon the technology choice. The technology choice can be reduced to one of two types; PON, passive optical networking, and Giga Bit Ethernet, GigE. It has been shown elsewhere that they are both conceptually similar but have differing performance characteristics.

2.1 Design Constraints

The major design constraints are:

1. Total population: This is the total population of the town. The penetration of actual customers and their geographical distribution will be part of the market research effort. Moreover there may be certain sections of the town which are unreachable.
2. Total number of streets: The total number of served streets is critical. There may be large commercial areas or areas long in length which are not targets for the FTTH service. These must be identified. Commercial street locations may, however, be targets for commercial service provisions.
3. Frontage: The frontage is the average length of the front of a HH. It is a measure of local HH density. Large frontages may be an added cost to capital plant deployment.
4. Drop Lengths: The drop length is the distance from the point of the fiber on a pole to a local household. The drop may be aerial or buried. The nature of the buried fiber may also be a key cost element. Long drop lengths may be exceedingly costly.
5. Total Mileage: Total road mileage will be a key factor in the design. The “served” mileage will, however, be the driving factor.

2.2 Design Inputs

The following table depicts the key design inputs.

<i>Design Input</i>	<i>Implication</i>
Total Miles of Streets	This is the total street miles. It also requires a detailed analysis of what streets must be covered, a timing of the streets deployment and a preliminary discussion of commercial areas.
Total Number of Households	This is the total HH count. It is important to understand HH counts and user counts. Namely there may be student or multiple HH residences.

<i>Design Input</i>	<i>Implication</i>
<p>Services Desired:</p> <ul style="list-style-type: none"> -Broadband Internet Access -Video, Analog and Digital -Telephony 	<p>The actual services required must be factored into the overall design. This is a question of both service demand in size as well as timing. Also a detailed definition of the services will be required. This report focuses only on an IP supported infrastructure.</p>
<p>Anticipated Location of Headend</p>	<p>The headend is “anticipated” to be at a certain location. Clustering of headends over multiple towns is also a strong possibility. This will be considered in detail in the later stages of the design process.</p>
<p>Streets Identified for Initial Build</p>	<p>The initial build streets must be identified for each quarter for the first two years. In this model we have done so in a generic fashion. For the definitive model this will need further work.</p>
<p>Percent Aerial Construction</p>	<p>This is a measure of the percent of fiber which can be deployed on telephone poles.</p>
<p>Percent Buried / Trenched Construction</p>	<p>This is the percent of fiber which must be buried.</p>
<p>Who Owns Poles and Aerial Rights of Ways?</p>	<p>The pole ownership must be clarified. Although not a key element of this study it will be a key element in understanding the ultimate study results.</p>
<p>Who Owns Buried Rights of Ways?</p>	<p>This is the same set of issues as regards to pole rights.</p>
<p>Total Number Poles</p>	<p>This is the development of a data base of all poles, who owns them, where they are, what is on the poles, and an estimate of any and all make ready issues.</p>
<p>Average Distance Between Pole</p>	<p>This distance may be a standard for the town but should be understood at least on the sector level.</p>
<p>Pole Identification Numbers by Streets</p>	<p>This is the data contained in the pole data base.</p>
<p>Average Setback of Homes</p>	<p>The setback is from the street but is typically measure from the nearest pole of buries access point. Thus setback is the gross effective setback measurement.</p>

<i>Design Input</i>	<i>Implication</i>
Known "Make-Ready" Issues	Make ready costs and times must be further understood. The model uses standard make ready costs for the region. Generally these are fairly consistent but must ultimately be reduced to a definitive number.
Is Electrical Space Available for Fiber Run?	The basic availability of space is a key issue. No space, no deployment. In most towns of interest this is not a problem but must be ascertained.

2.3 Design Performance Issues

The following are the proposed performance factors for the design.

<i>Performance Factor</i>	<i>Measure</i>
Reliability	99.9%
Mean Time to Repair	< 2 hours
Delay or Latency of Packets	< 10 ⁻⁶ sec
Maximum Downlink Data Rate per HH	100 Mbps
Maximum Uplink data rate per HH	100 Mbps
Minimum Downlink Data Rate	10 Mbps
Minimum Uplink Data Rate	10 Mbps
Bit Error Rate	Less than 10 ⁻⁹

2.4 Design Methodology

The design methodology used in this study is intended for a feasibility study analysis and not a detailed design analysis. The basic elements are:

1. Sectorization of the network into sectors of generally comparable population and generally contiguous streets or accessibility.
2. Field evaluation of the frontage, set back, aerial percentages, make build costs, and drop availability using a photo data base and sampling techniques is performed.
3. Data analysis of field information to develop a sectorized financial model.
4. Use of two basis technologies, PON and GigE, and using averaged industry pricing numbers for the development of a pricing model for all capital plant.
5. Overall network optimizations and analysis using field data, vendor average price data, and optimized design methodologies for a capital plant deployment cost analysis.

3. ANALYSIS OF PLANT BUILD

This section details the basic design and analysis methodology. It must be repeated that this is a Feasibility study and not a detailed design study. It is most likely that any third party making a bid to perform the work discussed herein may have a different design and in addition there may be added design factors which may not have been included herein.

Thus the methodology chosen is used for feasibility analysis only.

3.1 Methodology

The methodology is composed of several elements. The approach consists of the following steps:

1. Establishment of Headend.
2. Sectoring the town. This step breaks the town into sectors of no more than 1,500 HH and has sectors with generally consistent characteristics.
3. Establish of the network elements.

3.1.1 Headend

The headend is the key location for the central interconnection of all inbound and outbound communications. The headend is selected for each town although it may be possible to combine headend for common towns.

3.1.2 Network Elements

The network is a series of a bundle of fibers. A typical bundle may have upwards of 48 strands of fiber. The end goal is to have a strand or strand pair per HH. The ability to perform this interconnection is based upon the integration of three units; the CSU, the FSU, and the EEU. The CSU is the main interconnection point, the FSU is a branching and sharing point, and the EEU is in the household.

The network has the following elements:

Central Service Unit (CSU): This unit provides for the interconnection of any and all inbound and outbound communications. The unit had a fixed initial capacity, say 8,000 users, and a variable capacity say 2,000 users per new unit element. These numbers will vary depending on the vendor. The CSU provides for interconnectivity of all services and its price and variability will depend upon the service mix. The CSU is in the headend.

Field Service Unit (FSU): The FSU interconnects a single or pair of fibers to multiple bundles of fiber. The fibers coming from the CSU are carrying a high speed data backbone service of 1 Gbps or greater in both directions. The FSU then shares this amongst multiple outbound fiber bundles. The FSU has a fixed costs element for a minimal number of outgoing fiber bundles and a variable amount. In addition the FSU has a maximum capacity of outgoing fiber bundles. The FSU is a branching element which "shares" the bandwidth or data rate on the backbone with all end users on the final terminating leg. This is generally the bottleneck in any network. In PON designs this is fixed and in GigE this can be dynamically managed.

End User Unit (EUU): The EEU is the household interconnection device. It connects to the fiber or fiber pairs and then to the in home internet access, telephony, or video.

The typical network is shown below:

Basic Architecture

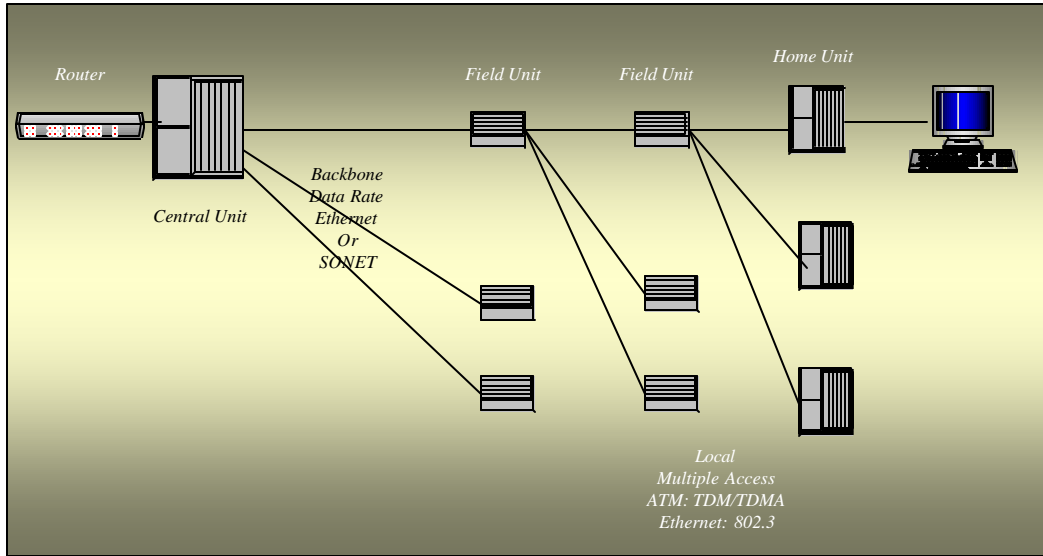

3.1.3 Sectorizing

Sectorizing is based upon two factors:

1. Maximum capacity per single fiber bundle.
2. Commonality and clustering of proximate neighborhoods.

As stated above, the FSU has a maximum capacity. This again depends upon the specific vendor and technology. However, this means that sectors must be no larger than a single FSU capacity. The design initially starts with 50% or less maximum loading per sector. It should be noted that new sectors can be added at any time if additional capacity is required.

The second issue is that the sectors should have some commonality in terms of end users; household since, setback, frontage, aerial or otherwise, or other similar factors.

3.1.4 Network Layout

The network is deployed with an initial deployment of a fiber bundle to each sector which connects to an FSU in each sector.

The three elements are shown below. They figure generally depicts the three elements of trunk, feeder and drop. The financial model uses this nomenclature and build costs elements.

Generic Fiber Network Elements

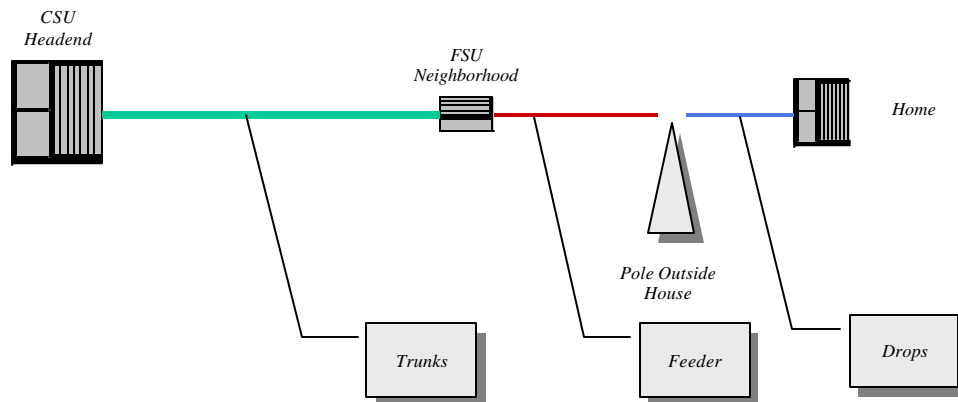

3.1.4.1 Trunking

Trunks are from the headend to the FSU. They are the high speed backbone elements of the network. The general scheme is a trunk is co-located with a sector. There may be more than one trunk per sector, however. In the initial designs a trunk and a sector are unique. The trunk has 48 fiber bundles, each fiber going to a FSU. The trunk may be most likely aerial. It will typically follow a major road but that will often be determined by the make ready costs associated with the poles on that route.

3.1.4.2 Feeders

From each FSU to each home there is a set of feeder cables. The feeders are sets of bundles emanating from a FSU. The number of bundles, and in turn the number of feeder cables will depend on technology but multiple ones are possible. Thus with a 48 strand trunk, and having a minimum of say 2 feeder per FSU, one can achieve 2X48X48 HH to be served, or 4,608 HH with that design alone.

3.1.4.3 Drops

The drops are the strand from the feeder to a single household. The drops are measured in what is termed set back distances. Whereas the trunks are typically 10-20% of the total road mileage, and the feeders make up the rest, the drops may become a significant additional set of build if the build requires large set back distances.

3.2 Results

This subsection details the overall design based on the field analysis. On March 31, 2003, the Merton team made field analysis of all of Belmont. The town was sectored and each sector had a drive through. Data were recorded both quantitatively as well as with images. The image date is shown in the final section of this report.

3.2.1 Sector Design

The following figure depicts the Belmont sector map. The town was divided into 5 sectors. They are shown on the map which is contained in the following.

Based upon the field analysis, the following map shows the network trunk network design. Feeders are then brought out to serve the remainder of the sectors.

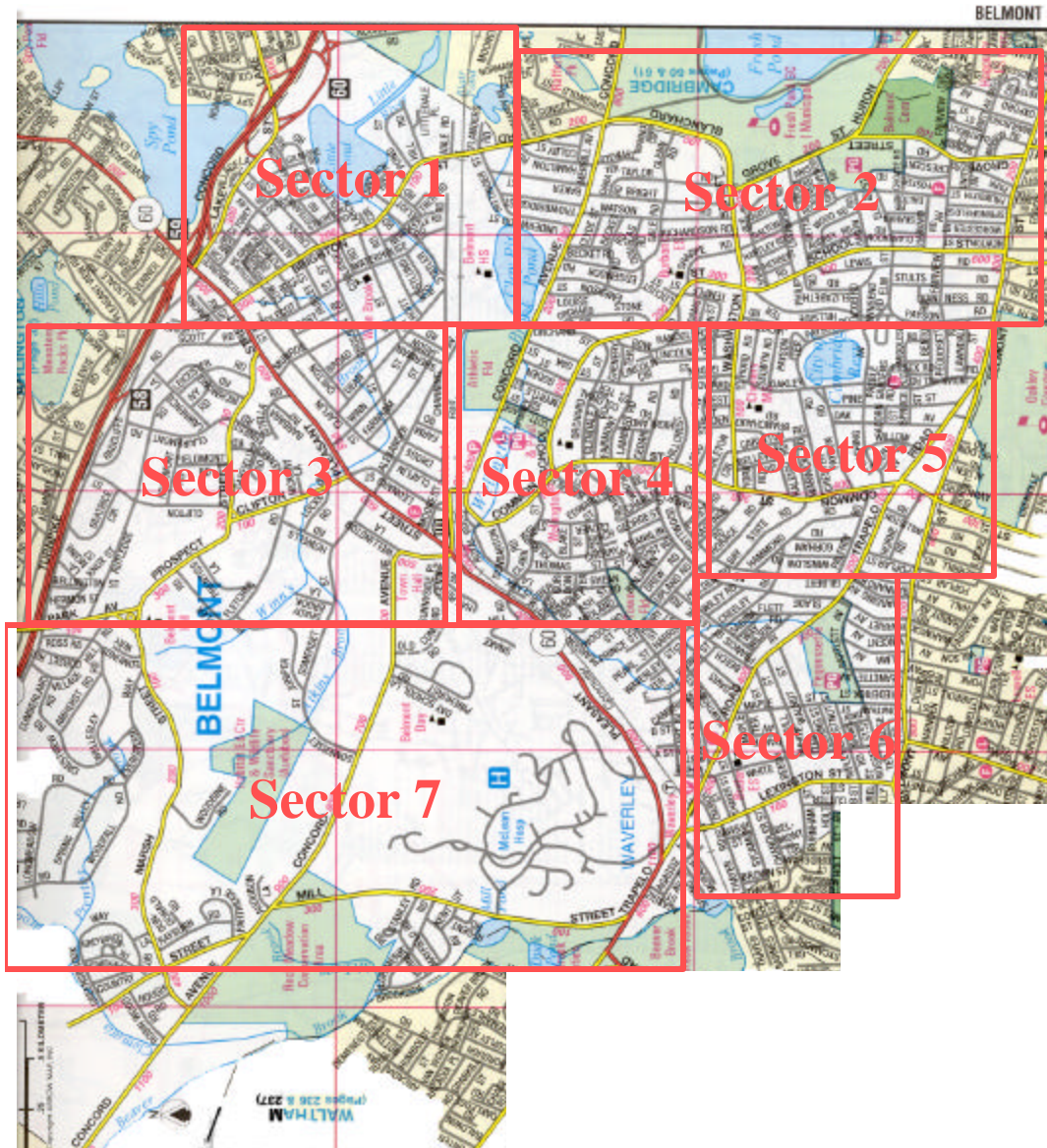

3.2.2 Basic Network Build Data Analysis

The following data depicts the network summary data for each sector. The raw data is contained in the end of this report.

The first table, shown below, depicts the overall breakout for the town. It is an estimated population and street mile count per sector. These numbers will be used with the field data to estimate the sector setback, aerial and make ready requirements. It is important to reiterate that the data are samples with feasibility study accuracy. The results are not to be relied upon for a definitive build. In that latter case, it will be required to perform a detailed design study.

Sector	Population	Percent	Street Miles	Percent
1	2,134	22%	14	16%
2	1,746	18%	16	18%
3	1,455	15%	15	17%
4	1,455	15%	13	14%
5	970	10%	11	12%
6	970	10%	11	12%
7	970	10%	10	11%
		100%	90	100%

Total HH: 9,700
 Total Miles Streets: 90

3.2.3 Setback

The following table depicts the summary analysis for the setback. As expected, some regions have significant set back and others are small. The average setback is shown in the analysis.

Sector	Street Miles	Average Set Back	Weighted Average Setback
1	14		-
2	16		-
3	15	150	39
4	13	50	11
5	11	50	9
6	11	50	9
7	10	75	13

Total Average Set Back 80

3.2.4 Make Ready

A similar analysis has been performed on the make ready amounts. Significant make ready is required in some areas. However, the overall make ready is less than 30%.

Sector	Street Miles	Average Make Ready	Weighted Average Make Ready
1	14	0%	0%
2	16	0%	0%
3	15	0%	0%
4	13	0%	0%
5	11	0%	0%
6	11	0%	0%
7	10	0%	0%

Total Average Set
Back 0%

3.2.5 Aerial

The amount aerial has also been calculated. The town is mostly aerials so the requirements for buried is minimal.

Sector	Street Miles	Average Aerial	Weighted Average Aerial
1	14	100%	16%
2	16	100%	18%
3	15	100%	17%
4	13	100%	14%
5	11	100%	12%
6	11	100%	12%
7	10	93%	10%

99%

4. SYSTEM DESIGN

This section is a brief overview of the technology deployed in the case of MBN.

4.1 System Elements

The basic architecture for PON or Gigabit Ethernet is shown below. The elements are:

1. Central Unit: This is at a headend or some similar central location and provides for central management and interface.
2. Field Units: These units are the n:1 splitting devices, active or passive, which take a backbone signal and share it amongst several home units. In GigE the backbone rate is 1 Gbps down and up using two fibers, in ATM PON it is a single fiber using several wavelengths, one up and one down, using SONET and ATM formats. SONET is a layer 1 protocol.
3. Home Units: These are the devices in the home made to support data, voice, and video.

Basic Architecture

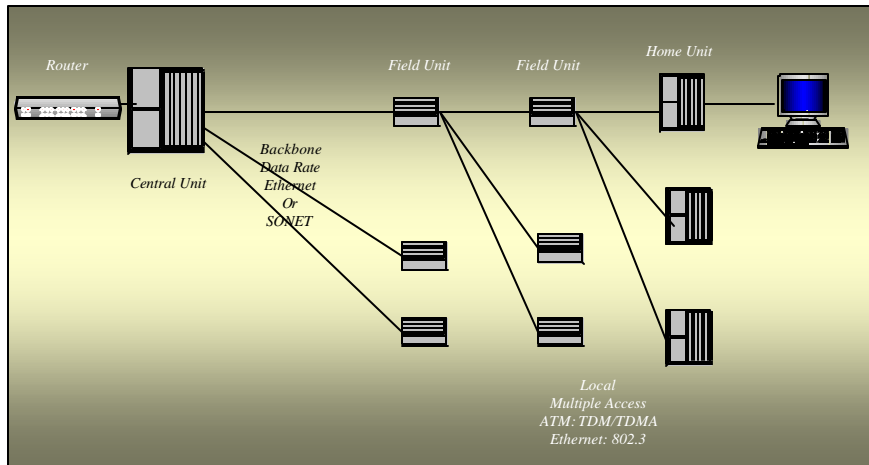

4.2 Key Definitions

Before describing the PON and GigE designs, several key terms and concepts must be reviewed. This section performs that review.

Protocols: Protocols are agreed to standards for the purpose of establishing communications between two or more computers. Frequently, protocols are developed in what is called Standards Bodies, so that most manufacturers agree to build to the standard.

Layer 1: Layer 1 are the physical protocols that have been agreed to so that one can interconnect different equipment. The simplest example is the RJ 11 plug used to connect telephones and modems. Layer 1 relates to physical types of things. It also relates to signalling such as modulation of signals.

Layer 2: This is the first layer which sits above Layer 1 and allows machines via the content, and position of certain logical bits of data, to talk with one another. Layer 2 describes where data is and where control information is. It further describes what to do with the information at all ends of the communications link.

ATM, Asynchronous Transfer Mode: Now ATM is a layer 2 protocol, it is what is below IP and IP is below TCP; this is in reality a concatenation of overheads, each with their own functions. ATM frames have lots of overhead for such things as quality control and services level administration. ATM was built by telephone people not computer people, it was a higher speed way to interconnect telephone switches as we knew them in the early 1990s. It did not anticipate such things as IP telephony.

Ethernet: Ethernet is another layer 2 protocol. Unlike ATM, which is a rigid frame oriented approach, Ethernet uses the maximum capabilities of packets of variable size and has the ability to optimize the throughput. It also has the flexibility to allow varying data rates. ATM, on the other and, is rigidly controlled to telephone controlled data rates. For example, Ethernet works to 10 Gbps and higher, whereas, ATM uses the DS or OC formats of 155 Mps, or 622 Mbps.

TDM, Time Division Multiplexing: TDM is a way of communicating from one user to many others, or between many others. When the master users sends data to many smaller ones, it can do so in separate sequences of the overall data frame. Each sequence has its time slot.

TDMA, Time Division Multiple Access: TDMA is another approach but tuned for communicating from many small users simultaneously to a large one. In this case each small user may demand in some fashion its own time for a packet and then send it in that demanded time slot. Unlike TDM, which has all communications in a large packet, TDMA is an agglomeration of small independent but coordinated packets.

Layer 2 Switch: This is a device which switches layer 2 protocol packets.

TCP/IP: The IP protocol, Internet Protocol, is a layer 3 method to send packets of information from one place to another using a very simple network in between. In the world of IP the “intelligence” all resides at the edge of the network and the inside of the network is as simple as possible. IP is the basis of that simple network. IP headers are simply the set of information bits that are on any packet that tells it how to go from one point to another. TCP, is a layer 4 protocol which insures that the communications is controlled end to end. TCP/IP is the key technology for all data communications.

QoS, Quality of Service: QoS is a term which means that things go well at a certain level. It is one of the vaguest terms in communications. Each providers specifies their own QoS.

4.3 Passive Optical Networking

Passive Optical Networking, PON, is a method of sharing a bandwidth or data flow on a fiber strand amongst multiple HH at the same time. It does so using two elements; a layer 2 approach using TDM and TDMA in an ATM format, plus an all passive optical distribution network which connects N HH to a single fiber. It is passive and in a certain way is less adaptive than active schemes. It uses ATM, the asynchronous transfer mode layer 2 approach to control the data flow by using large ATM frames

and more importantly using the ATM quality of service, QoS, control features. This is critically important in such areas as video on a data layer.

An optical distribution network with ATM PON as the core technology promises benefits to end users as well as carriers and service providers. When optical network access is achieved in scale, businesses and consumers will realize opportunities for advanced services at relatively low costs. Because of potential cost savings inherent with the ATM-PON platform, telecommunications carriers and service providers will realize efficiencies in provisioning future applications and upgrading bandwidth to satisfy customers' demands.

In general, the optical section of a local access network can either be a point-to point, ring, or passive point-to-multipoint architecture. The main component of the PON is an optical splitter device that, depending on which direction the light is traveling, splits the incoming light and distributes it to multiple fibers or combines it onto one fiber. The PON, when included in FTTH/B architecture, runs an optical fiber from a CO to an optical splitter and on into the subscriber's home or building. The optical splitter may be located in the CO, outside plant, or in a building. FTTCab architecture runs an optical fiber from the CO to an optical splitter and then on to the neighborhood cabinet, where the signal is converted to feed the subscriber over a twisted copper pair. Typically, the neighborhood cabinet is about 3 kft from the subscriber's home or business.

The following figure depicts the typical PON architecture. It follows the generic form shown earlier. It includes a headend as the master unit, a set of FSU devices which are passive splitters of optical data, and an end user unit.

The PON system works in the following fashion:

- 1. Data from the headend goes down the backbone fiber using an ATM format and has a TDM layer 2 ability to send to all the end users. TCP/IP may ride above the ATM layer 2 level.*
- 2. The signal is 622 Mbps down and 155 Mbps up from the HH. This was defined many years ago by the RBOCs, the monopoly telephone companies. In many ways this is a telephone design, not a data design.*
- 3. At the splitter, the data is split by an optical splitter to 8 sectors of outgoing fiber.*
- 4. Each strand is then sent to HH by taps which allow drops from the strand to the HH. There are in each Subsector, 24 strands which go to 24 HH maximum.*
- 5. The major problems here are limited backbone data rates and possibly limited HH rates since the 622 down is shared amongst many users as is the 122 uplink. This also means that having the ability to do in home hosting of web sites etc may be severely limited.*

PON Scheme

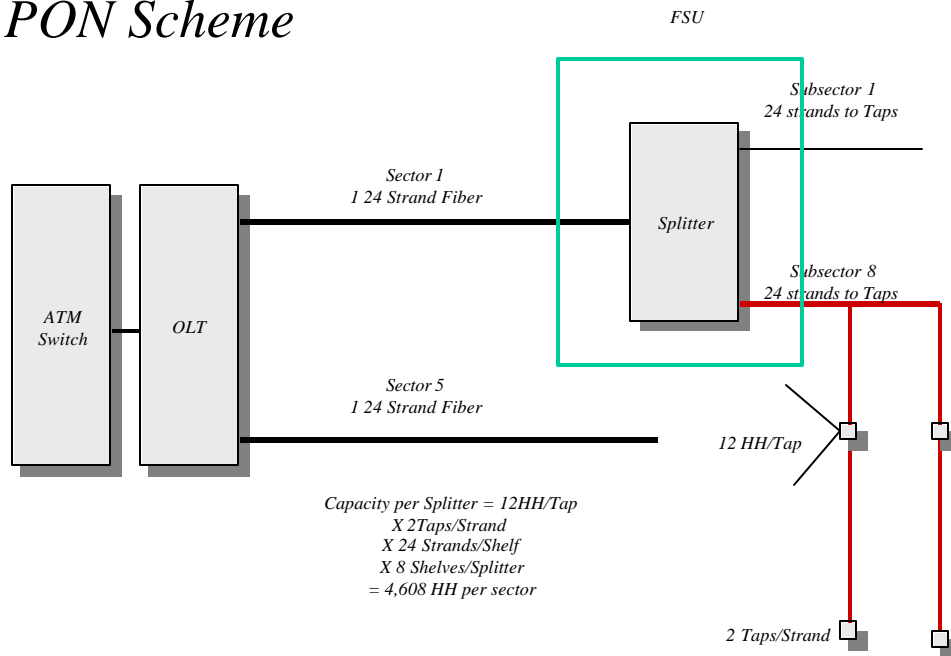

It must be noted that ATM is used as the layer 2 protocol on the entire network. ATM provides a QoS capability. ATM is 622 Mbps down to the effective FSU, which is the splitter above, and is 155 Mbps up from the splitter. The layer 2 approach is TDM from the FSU to the EUU, and TDMA back. However, it is critical to understand that in this design of an ATM PON system, the 622 and 155 Mbps are then shared to all HH equally and on a pro rata basis. This may drastically reduce the overall effective data rates. The passive FSUs, the splitters, have no power and are thus low maintenance, but in addition have no intelligence and are limited.

When fiber is used in a passive point-to-multipoint (PON) fashion, the ability to eliminate outside plant network electronics is realized, and the need for excessive signal processing and coding is eliminated. The PON, when deployed in an FTTH/B architecture, eliminates outside plant components and relies instead on the system endpoints for active electronics. These endpoints are comprised of the CO-based optical line terminal (OLT) on one end and, on the other, the optical network termination (ONT) at the subscriber premises. Fiber-optic networks are simple, more reliable, and less costly to maintain than copper-based systems.

One optical-fiber strand appears to have virtually limitless capacity. Transmission speeds in the terabit-per-second range have been demonstrated. The speeds are limited by the endpoint electronics, not by the fiber itself. For the ATM-PON system today, speeds of 155 Mbps symmetrical and 622 Mbps/155 Mbps asymmetrical are currently being developed. As the fiber is not the constraining factor, the future possibilities are endless. Furthermore, because fiber-optic technology is not influenced by electrical interferers such as cross-talk between copper pairs or AM band radio, it ensures high-quality telecommunications services in the present and future.

4.4 Gigabit Ethernet

Gigabit Ethernet, GigE is the non-passive version. It uses a similar FSU concept but now the switching is not in the ATM layer but in an Ethernet layer 2 switch which is out in the field. Moreover, the data rates to the switch are at a minimum 1 Gbps which the switch and adaptively and in a real time fashion allocate across users. The Ethernet capability adds a significant positive dimension to flexibility and connectivity. However it does so at the cost of a powered active component.

Gigabit Ethernet standards, the IEEE 802.3 type, are fully compatible with existing Ethernet installations. It retains Carrier Sense Multiple Access/Collision Detection (CSMA/CD) as the access method. It will support full-duplex as well as half duplex modes of operation. Initially, single-mode and multi mode fiber and short-haul coaxial cable will be supported.

Gigabit Ethernet is deployed as a backbone in existing networks. It can be used to aggregate traffic between clients and "server farms", and for connecting Fast Ethernet switches. It can also be used for connecting workstations and servers for high - bandwidth applications such as medical imaging or CAD.

Ethernet employs the IEEE 802.3 standard for a CSMA/CD LAN. The network architecture for GigE is shown below. It has the ability to use a minimum of 1 Gbps on the backbone and has the ability to upgrade to 10 Gbps. The local loops to the HH are a minimum of 100 Mbps and upgradeable to 1 Gbps. This is in stark contrast to PON which is a sharing network and limited to 622 Mbps and 155 Mbps on the backbone links which are then shared. The cost of the increase if the use of active components on the FSU as well as the loss of service QoS management since ATM is not employed.

System Elements GigE

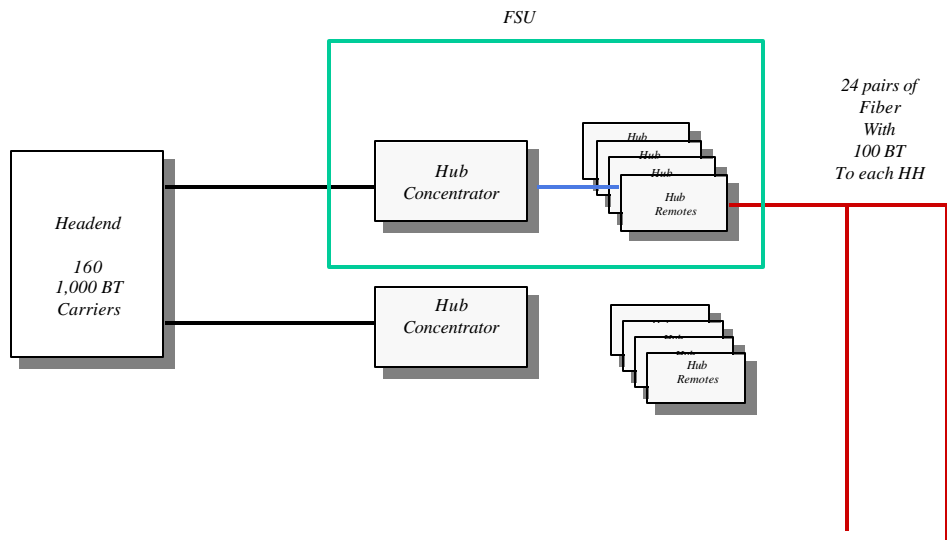

4.5 PON/ATM vs. Gigabit Ethernet

When PON/ATM (Asynchronous Transfer Mode) was introduced, it offered 155 Mbps bandwidth, which was 1.5 times faster than Fast Ethernet. ATM was ideal for new applications demanding a lot of bandwidth, especially multimedia. Demand for ATM continues to grow for LAN's as well as WAN's.

On the one hand, proponents of PON/ATM try to emulate Ethernet networks via LANE (LAN Emulation) and IPOA (IP over ATM). On the other, proponents of Ethernet/IP try to provide ATM functionality with RSVP(Resource Reservation Protocol) and RTSP (Real-time Streaming Transport Protocol). Evidently, both technologies have their desirable features, and advantages over the other. It appears that these seemingly divergent technologies are actually converging.

PON/ATM was touted to be the seamless and scaleable networking solution - to be used in LANs, backbones and WANs alike. However, that did not happen. And Ethernet, which was for a long time restricted to LANs alone, evolved into a scalable technology.

PON/ATM still has some advantages over Gigabit Ethernet :

1. PON/ATM is already there. So it has a head start over Gigabit Ethernet. Current products may not support gigabit speeds, but faster versions are in the pipeline.
2. PON/ATM is better suited than Ethernet for applications such as video, because ATM has QOS (Quality of Service) and different services available such as CBR (constant bit rate) which are better for such applications. Though the IETF (Internet Engineering Task Force, the standards body for internet protocols) is working on RSVP which aims to provide QOS on Ethernet, RSVP has it's limitations. It is a "best effort" protocol, that is , the network may acknowledge a QOS request but not deliver it. In PON/ATM it is possible to guarantee QOS parameters such as maximum delay in delivery.

Gigabit Ethernet has its own strengths :

1. The greatest strength is that it is Ethernet. Upgrading to Gigabit Ethernet is expected to be painless. All applications that work on Ethernet will work on Gigabit Ethernet. This is not the case with ATM. Running current applications on ATM requires some amount of translation between the application and the ATM layer, which means more overhead.
2. Currently, the fastest PON/ATM products available run at 622 Mbps. At 1000 Mbps, Gigabit Ethernet is almost twice as fast. In addition, GigE is readily upgraded to 10 Gbps, standards for which already exist.
3. It is not clear whether any one technology will succeed over the other. It appears that sooner or later, ATM and Ethernet will complement each other and not compete.
4. Gigabit Ethernet is the third generation Ethernet technology offering a speed of 1000 Mbps with the ability to upgrade to 10 Gbps. It is fully compatible with existing Ethernets, and promises to offer seamless migration to higher speeds. Existing networks will be able to upgrade their performance without having to change existing wiring, protocols or applications.

5. CAPITAL PLANT ESTIMATES

5.1 Cost Models

We can now apply these models to a GigE example. The following is an expanded version of the basic architecture applied to the GigE solution. We have detailed the fixed and variable elements.

5.2 Fiber Network Costs

The fiber costs are based upon a per foot cost element for comparable market deployments. The following table summarizes the key input assumptions to those cost elements which are used in the model. The details of the model have been show previously.

Element	Unit Cost
Aerial Engineering. + Construction Labor Cost per Foot	\$3.00
Trenching Engineering. + Construction Cost per Foot	\$8.00
"Make-Ready" Placement Cost per Foot	\$4.00
Fiber/Cable Material Cost per Foot - 2 Strands	\$0.10
Fiber/Cable Material Cost per Foot - 24 Strands	\$0.60
Fiber/Cable Material Cost per Foot - 36 Strands	\$0.70
Fiber/Cable Material Cost per Foot - 48 Strands	\$0.80
Fiber/Cable Material Cost per Foot - 96 Strands	\$1.00

5.3 Electronic Costs

The following demonstrates the detailed electronic elements and interconnections for the above basic architecture. The backbone is 1 Gbps active transport using 2 fibers per field unit, in this case called a hub.

5.3.1 PON Cost Elements

The cost elements for PON are detailed in the following chart. These are representative costs for the total network elements. Also shown are the capacities, maximum and minimum and the fixed and variable costs factors.

<i>Unit</i>	<i>Fixed</i>	<i>Variable</i>	<i>Capacity</i>	<i>Example for 1,000 HH</i>	<i>Per HH CAPEX</i>
EUU, End User Unit		\$1,000	1 per user	\$1,000,000	\$1,000
Taps		\$550	12 users per Tap	\$45,833	\$46
Splitter	\$7,000	\$1,250	8 splitter draws pre cabinet, 576 HH per splitter draw, maximum of 4,608 HH per Splitter cabinet. Typically 5 sectors so 5 splitters	\$41,250	\$41
ATM Switch	\$40,000	\$4,000	Max capacity 15 OC-3 Cards, incremental cost per OC-3 Card, user has 2 Mbps at 5% utilization is 100 Kbps per user.	\$44,000	\$44
OLT PON Card		\$6,000	Maximum 18 Cards per shelf, capacity of 64 users per card	\$93,750	\$94
OLT Rack		\$10,000	Maximum of 3 Shelves per rack. 3,456 HH per Rack	\$10,000	\$10
Number HH				1,000	
Total				\$1,234,833	
Total per HH				\$1,235	\$1,235
Total Fiber Miles		\$25,000	In town of 80 miles with 70% coverage	\$1,400,000	\$1,400
Drop Cost		\$300		300,000	\$300
Total per HH with Fiber					\$2,935

5.3.2 GigE Cost Elements

The following chart depicts the detailed GigE costs elements used in the analysis. They are based upon a compilation of current vendor analysis.

<i>Unit</i>	<i>Fixed</i>	<i>Variable</i>	<i>Capacity</i>	<i>Example for 1,000 HH</i>	<i>Per HH CAPEX</i>
EUU, End User Unit		\$1,000	1 per user	\$1,000,000	\$1,000
Remote		\$7,500	Supports 4 1 Gbps BT and 24 100 Mbps port pairs with 10 km range	\$312,500	\$313
Concentrator		\$7,000	Supports 16 1 Gbps BT connections at 10 km range	\$35,000	\$35
Headend	\$200,000	\$10,000	Supports 160 1 Gbps BT connections	\$210,000	\$210
Number HH				1,000	
Total				\$1,557,500	
Total per HH				\$1,558	\$1,558
Total Fiber Miles		\$25,000	In town of 80 miles with 70% coverage	\$1,400,000	\$1,400
Drop Cost		\$300		300,000	\$300
Total per HH with Fiber					\$3,258

5.4 Cost per HH

Then usage these elements we readily obtain the following capital requirements as we build out a network.

The following is the capex per subscriber as we expand the network. It is critical to note that this uses only a single headend and multiple hubs.

THE DATA SHOWN IN THE FOLLOWING SECTIONS IS NOT WHAT IS EXPECTED IN A FEASIBILITY STUDY. IT DOES NOT INCLUDE ANY SCALE ECONOMIES NOT DOES IT INCLUDE THE TIME VARIATIONS OF PRICES. IT DOES ASSUME A PRICE REDUCTION FROM LIST OF KEY ELEMENTS OF 30% WHICH IS TYPICAL. THE PRICE NUMBERS SHOWN BEFORE ARE VENDOR LIST PRICE, NOT THE NEGOTIATED PRICES. FIBER COSTS ARE AT LIST AND HAVE NO DISCOUNT SINCE THEY REFLECT WHAT THE CURRENT MARKET SUPPORTS. THE FOLLOWING NUMBERS ARE REPRESENTATIVE OF THE TECHNOLOGY CHOICES AND THE FACT THAT THE FIBER HAS GREAT SCALE WHEREAS THE ELECTRONICS DOES NOT.

5.4.1 PON CAPEX

The following is the CAPEX per HH for the PON design.

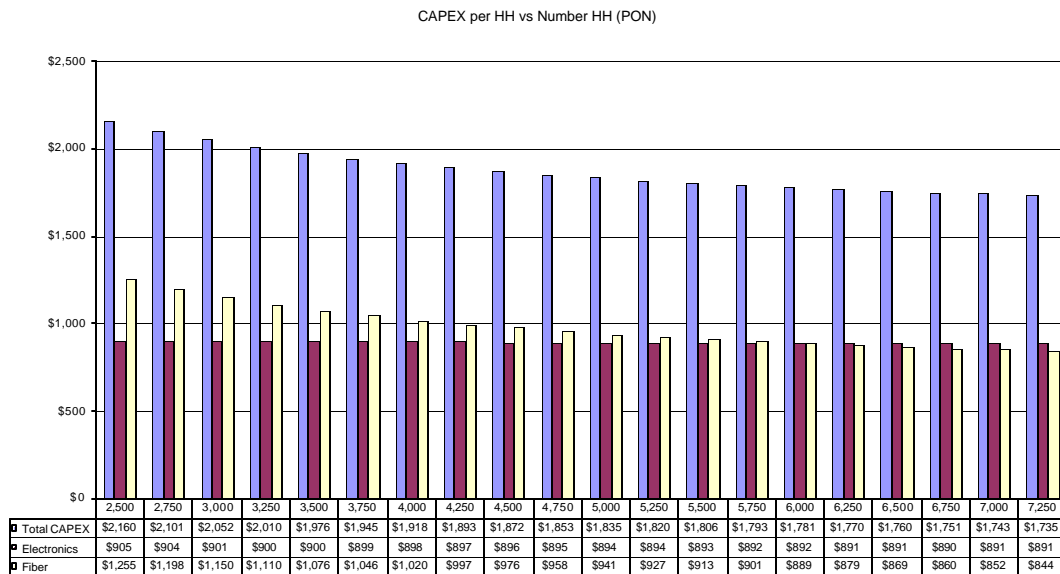

5.4.2 GigE CAPEX

The following is the expansion of this model to the GigE system design. This is for a capital per subscriber and it shows the increase of capex as new headend elements are added. The capex per subscriber has significant variability.

CAPEX per HH vs No HH (GigE)

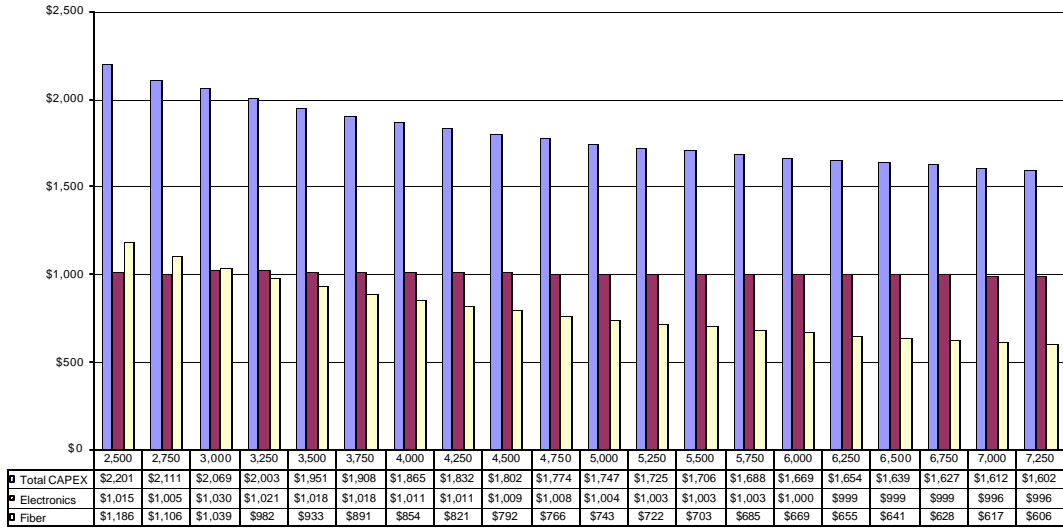

6. FIELD DATA

Town: Belmont Total HH: 9,700
 Date: 11-Apr-03 Total Miles Streets: 90
 Engineer: Eldredge

Photo	Sector	Avg Set Back	Aerial	Make Ready
1	3	300	0%	0%
2	3	150	100%	0%
3	3	100	100%	0%
4	3	100	100%	0%
5	3	100	100%	0%
6	7	75	100%	0%
7	7	75	100%	0%
8	7	75	100%	0%
9	7	75	100%	0%
10	7	75	100%	0%
11	7	75	100%	0%
12	7	75	100%	0%
13	6	50	100%	0%
14	6	50	100%	0%
15	6	50	100%	0%
16	6	50	100%	0%
17	6	50	100%	0%
18	6	50	100%	0%
19	6	50	100%	0%
20	6	50	100%	0%
21	6	50	100%	0%
22	6	50	100%	0%
23	4	50	100%	0%
24	4	50	100%	0%
25	6	50	100%	0%
26	6	50	100%	0%
27	6	50	100%	0%
28	6	50	100%	0%
29	5	50	100%	0%
30	5	50	100%	0%
31	5	50	100%	0%
32	5	50	100%	0%
33	6	50	100%	0%
34	6	50	100%	0%
35	6	50	100%	0%
36	6	50	100%	0%

7. DETAILED FIELD PHOTOS