

THE MERTON GROUP



Municipal Broadband Networks

Princeton Municipal Light Dept.

April 2003

NOT FOR DISTRIBUTION OR ATTRIBUTION

What is Municipal Broadband?

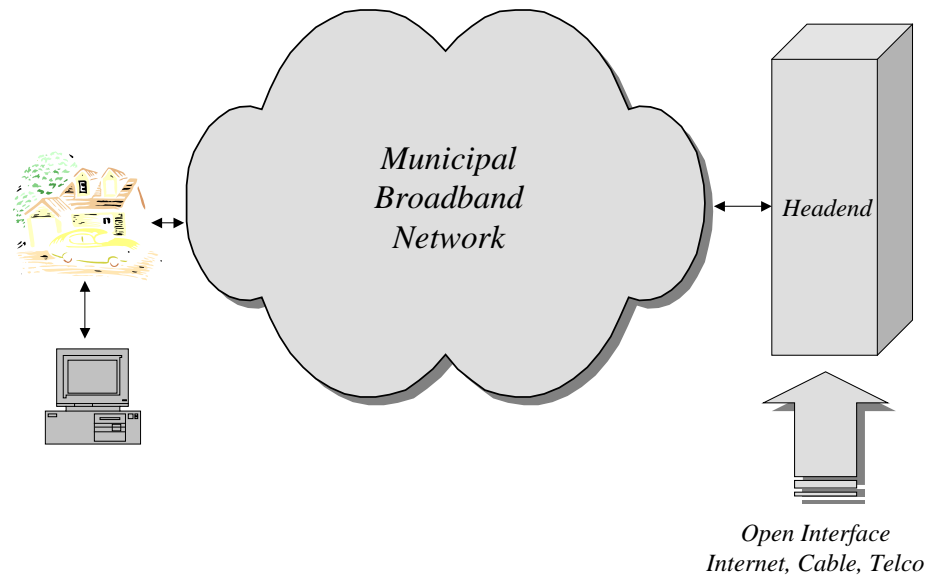

- *Optical fiber network owned by municipality (Town / Utility)*
- *Fiber connectivity to homes and commercial properties: 100 Mbps service, Fiber to the Home (FTTH)*
- *Integration of school, fire, police, public safety, healthcare*
- *Open access network allowing any service provider/ISP*
- *Municipality provides “bit” backbone only; service provider owns end-users*



Current Options for Broadband

Strengths

Weaknesses

	<ul style="list-style-type: none"> ✓ Incumbent network provider ✓ “Owns” all of the local customers 	<ul style="list-style-type: none"> X High borrowing cost of capital X Unbundling of broadband poses business risk to existing services X Significant cuts in budget X Politically complex
	<ul style="list-style-type: none"> ✓ Local CATV presence ✓ “Owns” the CATV customer 	<ul style="list-style-type: none"> X Very bad cash position X Need to upgrade cable plants to support two-way broadband in outlying areas
	<ul style="list-style-type: none"> ✓ Some broadband in larger cities and towns ✓ Some backbone infrastructure 	<ul style="list-style-type: none"> X Limited to no financial capability X Serious negative cash flow
<p style="text-align: center;">Municipal Network</p>	<ul style="list-style-type: none"> ✓ Capable of raising financing at low cost of capital ✓ Capable of local and targeted deployment ✓ No local regulatory problems 	<ul style="list-style-type: none"> X No network operational skills, but can be easily outsourced X No infrastructure support capabilities, but can be easily outsourced

Fiber-to-the-Home Services

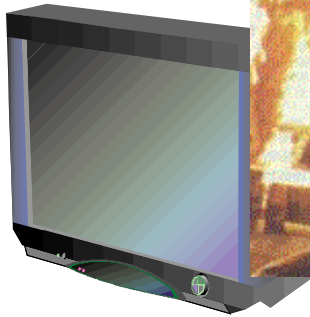

Video Services: Standard
And enhance video services
With HDTV digital TV
entertainment

Telephone Services: Access
To multiple telephone
services providers,
offering choice
And cost savings



Broadband Internet Access: 100 Mbps or greater; A secure, ultra high speed
network for family, municipal, medical, educational, public safety.



Service Providers: Choice & Competition



What are Returns and Risks?

Returns

*Immediate
New Revenue for Municipality*

*Improved Economic
Development Area*

*Enhance Services and Competitive
Environment*

Risks

*Bond Revenue:
Make Sign Up of Existing
ISP/s Prerequisite*

*Technology Choice and
Implementation:
Fiber Backbone*

*Competing New
Technology: Provide Open
Network*

Key Driving Factors

- *Revenue opportunity; money stays within the system*
- *Promotion of economic development through:*
 - *Competition and choice in data, video and voice*
 - *Facilitation of regional broadband applications*
 - *Distance learning & training*
 - *Telemedicine*
 - *Telecommuting*
 - *Public safety*
 - *Wireless / mobile access*
- *Creation of jobs through new businesses and services*
- *Improved quality of life for citizens through offerings of high quality services at lower prices*

Enable Aggregation

- *With collective action, achieve critical mass:*
 - *Achieve economies of scale in purchases, operations*
 - *Centralized need for expertise*
 - *Achieve sufficient size to attract service providers*
- *Make deployment decisions that make economic sense*
 - *Network must pay for itself; no taxpayer subsidies*
- *Outsource expertise to achieve scale economies*
- *Use most future-proof technology*

Key Demographic Factors for Municipal Broadband Success

Commercial Base

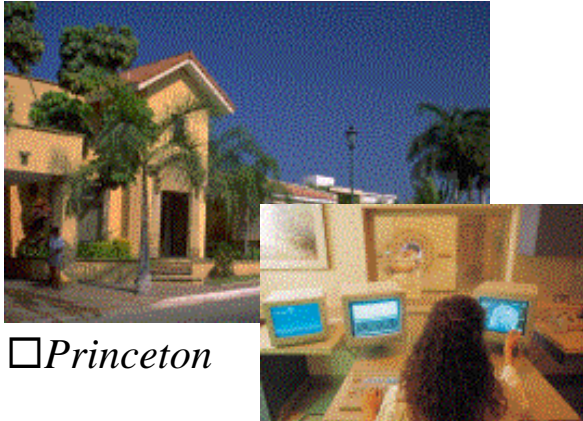

Princeton

*Good Demographics/
High Internet Usage*



Princeton

*Public Services and
Educational Usage*

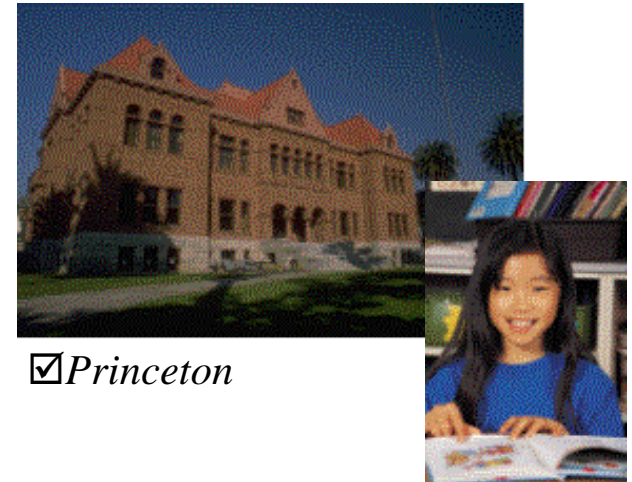

Princeton

High Density per Mile



Princeton

Demand for Enhanced Services



Princeton

Capital Costs Estimates

<i>Capital Cost</i>	<i>Assumption</i>	<i>Result</i>
<ul style="list-style-type: none"> • <i>Fiber Installation, New Trenching: \$50,000 per mile</i> • <i>Fiber Installation, Existing Conduits/ Aerial: \$20,000 per mile</i> 	<i>10%-90% split between new trenching and existing conduits/aerial</i>	<i>\$23,000 per mile</i>
<i>Fiber Cost: \$150 per mile per strand</i>	<i>48 strands on backbone 2 strands per home drop</i>	<i>\$7,800 per mile</i>
<i>Optical equipment and buried installations: \$7,000 per mile</i>	<i>Gigabit Ethernet Network architecture</i>	<i>\$7,000 per mile</i>
<i>FTTH drop and home electronics: \$900 per home</i>	<ul style="list-style-type: none"> • <i>Home has 100 foot frontage, or 60 homes per mile</i> • <i>30% penetration of homes, or 18 homes per mile serviced</i> 	<i>\$16,200 per mile</i>
<i>TOTAL</i>		<i>\$54,000 per mile</i>
<i>TOTAL per Home</i>	<i>18 homes per mile serviced</i>	<i>\$3,000 per Home Served</i>

Princeton Specifics

<i>Population</i>	<i>3,400</i>
<i>Household (Parcels)</i>	<i>1,170</i>
<i>Businesses</i>	<i>75</i>
<i>Pop. Density</i>	<i>90 / sq. mi.</i>
<i>Average HH Income</i>	<i>\$40,000</i>

Source: <http://www.state.ma.us/cc/princeton.html>

<i>Financial Estimates (Draft)*</i>	<i>Year 1</i>	<i>Year 10</i>
<i>Adoption Level Assumed</i>	<i>15%</i>	<i>55%</i>
<i>Capital for FTTH Buildout</i>	<i>\$1.6 million</i>	<i>\$30,000</i>
<i>Bond Financing</i>	<i>\$2.05 million</i>	<i>-</i>
<i>Revenues</i>	<i>\$90,000</i>	<i>\$330,000</i>
<i>Debt Service</i>	<i>\$90,000</i>	<i>\$160,000</i>
<i>Operating Expenses</i>	<i>\$40,000</i>	<i>\$85,000</i>
<i>Free Cash Flow</i>	<i>\$-40,000</i>	<i>\$85,000</i>

* Subject to results of Feasibility Study; only broadband Internet is considered (no video, etc.)

Revenue Sources: “Starting Point”

Sample Internet Statistics

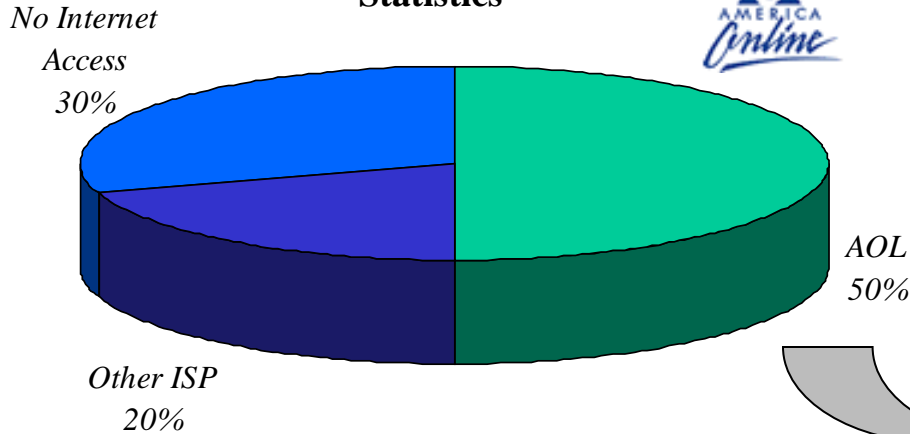

Number Telephone Lines (% of HH with AOL)

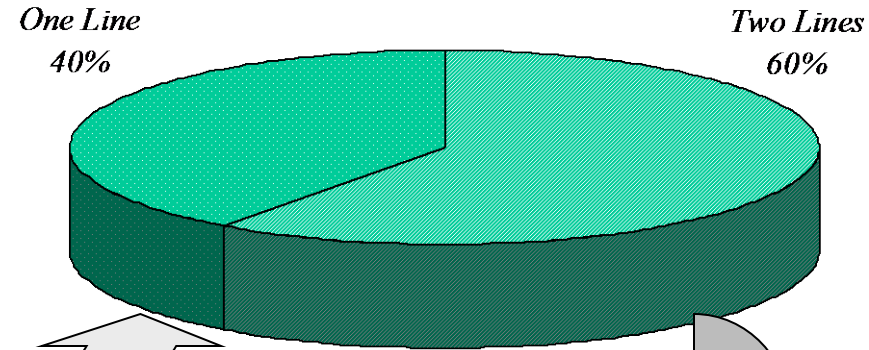

<i>Number Households (HH)</i>	<i>10,000</i>
<i>Number HH with AOL</i>	<i>5,000</i>
<i>Number HH with Second Line</i>	<i>3,000</i>
<i>Effective Conversion Rate</i>	<i>30%</i>
<i>Second Line Fee / Month</i>	<i>\$25</i>
<i>Revenue to Town (Annual)</i>	<i>\$900,000</i>

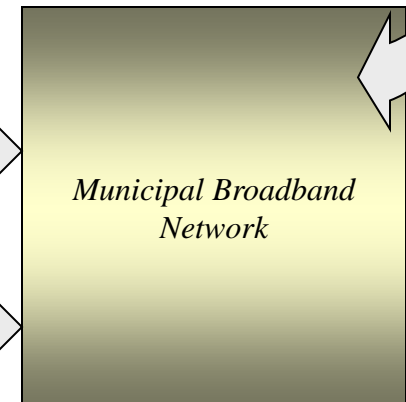

“Back of the Envelope”

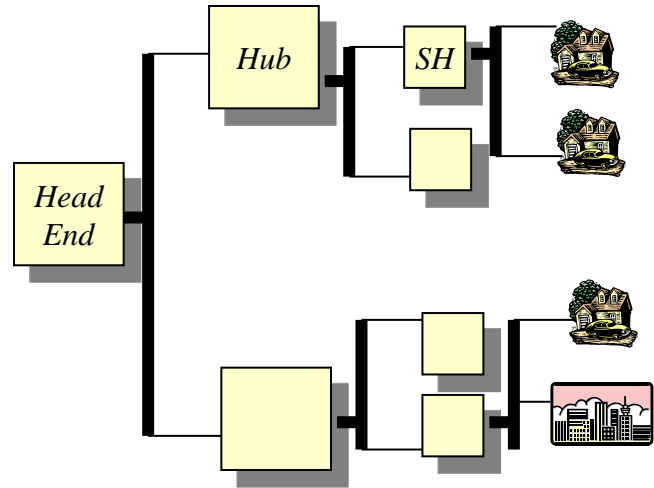

3,000 HH
 \$25.00 per month
 12 months/year
 = \$900,000
 Per year

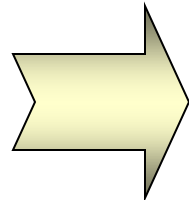

3,000 HH
 \$3,000 per HH
 = \$9,000,000
 For plant

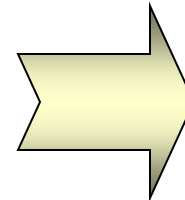

Payback Ratio

$$= \frac{\$9,000,000}{\$900,000} = 10 \text{ years}$$

Bond Interest Coverage = 160%
 (after Operating Expenses; Bond
 interest 4.25%)

Bond Coverage Example

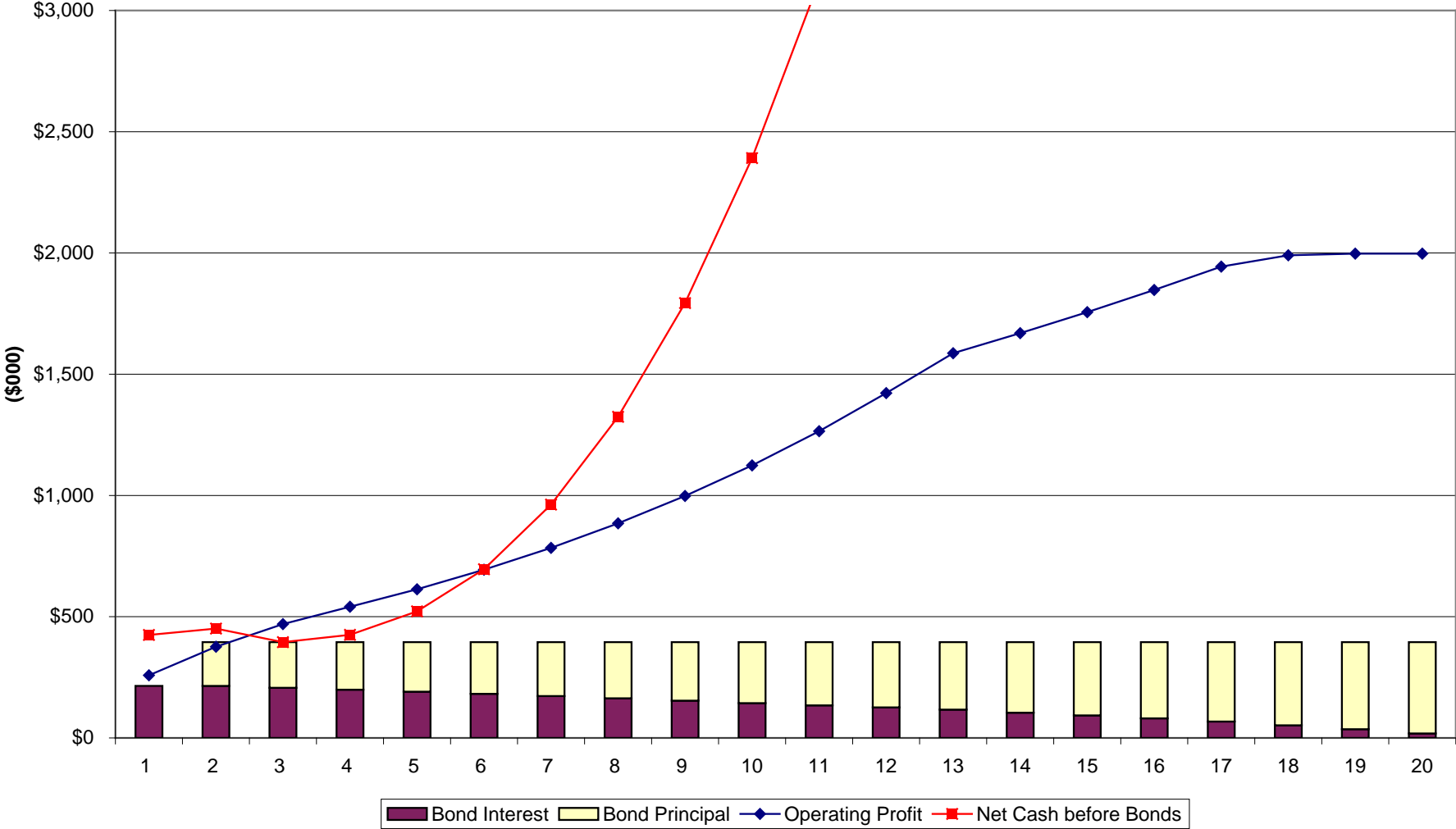

Payback Model

- *Not a quick Return on Investment (ROI) model*
 - *Industry targets ROI in 3-5 years*
- *Financing is long-term (20 years or more); expect 10 to 13 years payback period*
 - *Debt service*
 - *Capital Fund*
 - *Operations & Maintenance*
 - *Upgrades*

Feasibility Study Coverage

- *Market Research Analysis*
 - *Residential survey to determine market potential for enhanced broadband services*
- *Network Design*
 - *Architecture, technology, engineering issues*
- *Detailed financial analysis: revenues, capex, opex, etc.*
- *Revenue generation and bond coverage*
- *Regulatory and legal*
- *Opportunities and risks*

Schedule

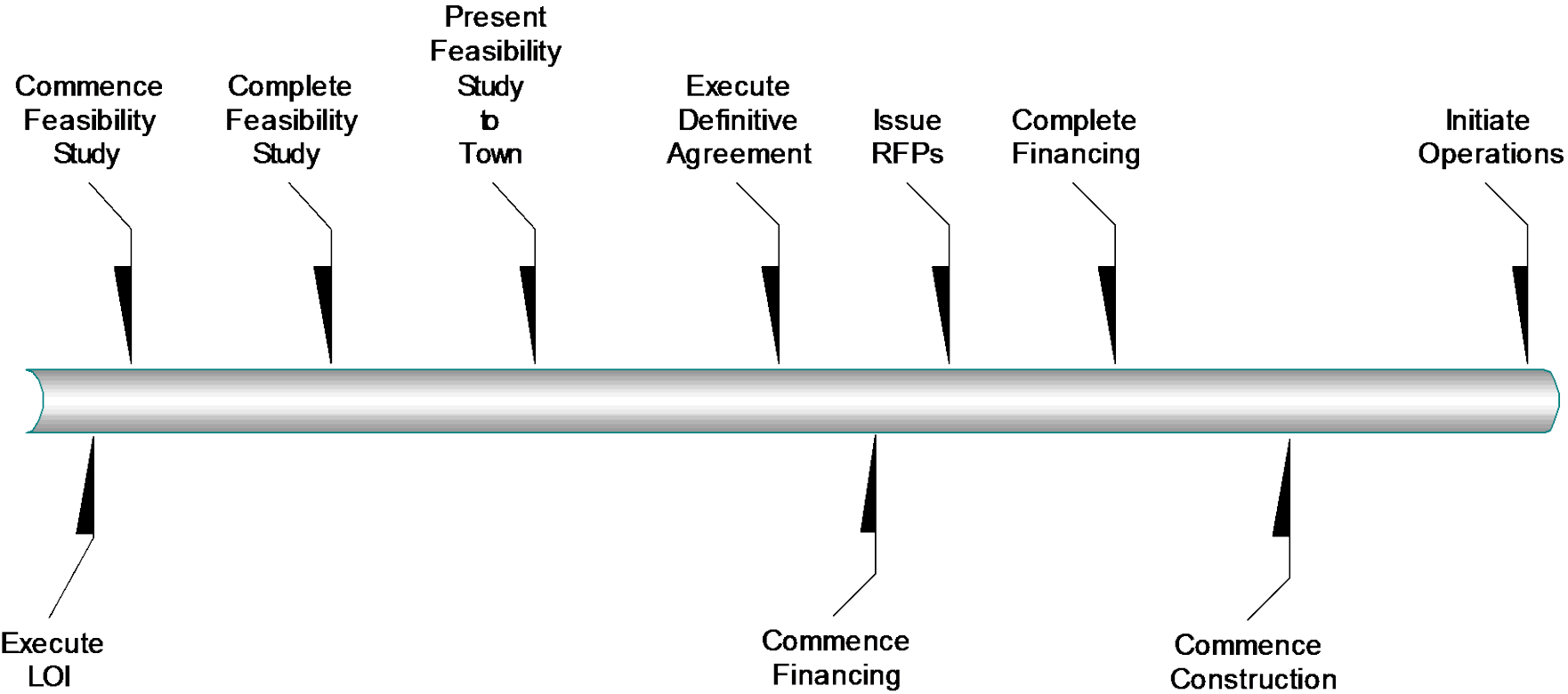

The Merton Group

Who we are:

- *Merton Group is a financial and operations management company focusing on development of enhanced Municipal Broadband Networks and services infrastructures*
- *Merton provides turnkey financial and operational advisory, management, and operations support facilities and services to finance, install, and operate fiber-optic broadband*
- *Merton is a “service integrator”*
- *Merton Principals are former executives from NYNEX/Verizon and CATV (Warner, now AoL Time Warner) and Goldman Sachs*

Our past experiences:

- *Financed, constructed and operated largest IP fiber network in Central Europe*
- *Structured and executed over \$1 billion of municipal bond financings*
- *Constructed and operated first Cellular network in New York and New England*
- *Constructed and operated multiple Operations Support Systems in US and Europe*
- *Initiated and successfully achieved regulatory change for interconnection from FCC*
- *Financed, constructed, and operated one of first CLECs in New England*
- *Successfully raised over \$200,000,000 in financing for start ups*
- *Successfully performed turn around operations on over two dozen companies*

Merton Services & Fees

Municipal Broadband Planning, Financing, Buildout and Operations

Project Management

- *Feasibility & Planning*
- *Financial Management*
- *Installation Management*

Fee as % of Gross Capital

Operations Support

- *Network Operations Center (NOC)*
- *Backbone/backhaul Support*

Fee per Active Subscriber

Sales Support

- *ISPs, CLECs*
- *Cellular Carriers*
- *Network Service Providers*
 - *Enterprises*
 - *Video Providers*
 - *Telco*

Fee as % of revenue above base