

# The Application of IP Telephony to Local Exchange Carriers<sup>1</sup>

Terrence P. McGarty  
The Telmarc Group  
Florham Park, NJ 07932

## Abstract

This paper presents an overview of IP technology to Local Exchange carriers. The paper expressly introduces a new architecture for the loop application, shows how there is a regulatory and operational advantage. The paper overviews the IP IVN technology, shows the network connections related to CLEC businesses and then shows how this can be implemented in a full network configuration.

## Contents

<b>1. INTRODUCTION.....</b>	<b>2</b>
1.1 SERVICE CHARACTERISTICS .....	2
1.2 SERVICE PROVISION.....	3
1.3 ARCHITECTURAL POSITIONING.....	4
1.4 THE IVN.....	5
<b>2. ARCHITECTURE.....</b>	<b>8</b>
2.1 ARCHITECTURAL ELEMENTS.....	8
2.2 SUBSYSTEM ELEMENTS.....	9
<b>3. ECONOMICS.....</b>	<b>11</b>
3.1 OPERATING ECONOMICS .....	12
3.2 TRADEOFF ANALYSIS.....	13
<b>4. REGULATORY.....</b>	<b>15</b>
4.1 THE 96' TELECOMMUNICATIONS ACT .....	15
4.2 US ADMINISTRATIVE CODE 47.....	17
4.3 PHILOSOPHICAL IMPLICATIONS .....	17
<b>5. CONCLUSIONS.....</b>	<b>18</b>
<b>6. REFERENCES .....</b>	<b>18</b>

---

<sup>1</sup> ©The Telmarc Group, LLC, 1997 All Rights reserved. Dr. McGarty is also Chairman and CEO of Zephyr Telecommunications an international record carrier.

## 1. INTRODUCTION

The development of the IP has provided a dramatically different set of alternative for the provision of long distance voice. Three factors have establishes this basis. First, the IP is a packet network that uses network resources only when these resources are required and not all of the time. Second, speech compression allows for the transmission of voice in a highly compressed form while retaining the quality that the consumer demands. This compression allows for the integration of speech with the IP. Third, technology is now available that allows for the simple integration of the normal telephone network with the speech compression systems and in turn with the IP. Thus the IP universality and low cost, the speech quality and ease of implementation, and the system proposed in this business plan, establishes a basis for a new and innovative market, namely long distance IP voice.

The current model for IP voice is to use one's own personal computer as the access point and then to access the IP and then to obtain the long distance service. New model are being developed that make four new key assumptions; first, to obtain universal access the use must access the system via their own telephone, even if that is a rotary dial telephone. Second, the access to the IP must be transparent to the user, namely they must just dial their numbers and never know that there is another virtual long distance carrier in place. Third, there must be all of the infrastructure elements in place, such as billing and customer service to ensure that the quality of the overall offering is a first class service. Fourth, the service must be of a sound and voice quality that is as indistinguishable from the telephone network as possible.

### 1.1 *Service Characteristics*

The service works as follows:

- *A customer calls the IVN from their local telephone.*
- *The IVN then provides for an IP connection between the calling party and the called party, via their Central Office. The called party is identified by a telephone number which is automatically matched with an IP address. The IP to IVN connection will identify calls attempting to terminate on this location.*
- *The IVN at the terminating location then out-dials the local number.*
- *The call is then completed and the call is monitored for time until termination and then a billing and system record are made for each call.*

This paper presents an overview of the potential for the IP voice business as may be applied to a domestic Competitive Local Exchange, CLEC, business. The key conclusions are as follows:

- *IP voice will have a cost structure that will be highly competitive with domestic local and long distance rates, exclusive of local access fees. Thus domestic IP voice is a strong competitor for domestic dial up long distance.*
- *The key to IP voice is the 8:1 speech or voice compression made in the IVN. This compression makes more effective use of any backbone network. This can be combined with a possible 10:1 concentration due to the remote positioning of line card capability in a Central Office co-location chamber. This results in an almost 80:1 utilization of interconnection facilities from a Central Office, CO, to the remote CLEC switch.*

- *IP economies come from the efficiency of transport and the efficiency and effectiveness of IP switching as well. All other long distance carriers face the same operations, sales, interconnection, and services costs. Thus the only cost element differential is backbone transport.*
- *Domestic inter-exchange traffic is a multi billion dollar business. Calls from any point in the US, or within any foreign country, are carried by IXCs, the inter-exchange carriers, and they costs about \$0.0550 per minute, of which \$0.0220 is now the access fee, this the full costs of IXC alone is \$0.0330 per minute. This cost is a combination of transport, switching, operations and SG&A. A simple calculation shows that SG&A is generally about \$0.0100 or less per minute, and decreasing, whereas switching and transport is almost \$0.0250 per minute. If one were to use IP then these costs can be reduced almost a factor of 10 or more!*

The architecture considered is quite simple. First it is NOT and Internet based architecture. It uses IP over dedicated transport facilities, facilities that allow for secure and clear channel IP transport. This eliminates the issues of lost packets, security threats, or other typical Internet related quality and performance problems. The network architecture connects IVNs via routers in a fully connected and possibly redundant network architecture.

The platform used in the provision of IP voice is the IP Voice Node, IVN. It is the integration of several technologies: (i) a Line Control Unit, LCU, routes call into and out of the system; (ii) the Voice Control Unit, VCU, compresses speech and converts it into a packet message to be transmitted via the IP; (iii) a Process Control Unit, PCU, which manages billing, provisioning and network management, (iv) a Transport Control Unit, TCU, which manages the flow of packets, (v) a Switch Control Unit, SCU, which manages the IP to NNX, telephone address, transformation, and, (vi) a router to effectively interconnect to and from the private network.

## **1.2 Service Provision**

The development of the IP has provided a dramatically different set of alternatives for the provision of local and long distance voice. The effectiveness of the IP or IP like networks is a result of three factors:

- *First, the IP is a packet network that uses network resources only when these resources are required and not all of the time.*
- *Second, speech compression allows for the transmission of voice in a highly compressed form while retaining the quality that the consumer demands. This compression allows for the integration of speech with the IP.*
- *Third, technology is now available that allows for the simple integration of the normal telephone network with speech compression systems and in turn with the IP.*

Thus, the IP universality and low cost, the speech quality and ease of implementation, and the system proposed in this business plan, establishes a basis for a new and innovative market, namely long distance IP voice. In this business plan, the provider uses IP "like" systems and may in certain circumstances use the IP itself. The provider employs an IP or private IP connection, to develop and operate a high speed backbone network.

The current model for IP voice is to use one's own personal computer as the access point and then to access the IP and then to obtain the long distance service. This plan make four key operational requirements;

- *First, to obtain universal access the use must access the system via their own telephone, even if that is a rotary dial telephone.*

- *Second, the access to the IP or provider provided IP must be transparent to the user, namely they must just dial their numbers and never know that there is another virtual long distance carrier in place.*
- *Third, there must be all of the infrastructure elements in place, such as billing and customer service to ensure that the quality of the overall offering is a high quality telephone service.*
- *Fourth, the service must be of a sound and voice quality that is as indistinguishable from the telephone network as possible.*

This approach is critically different than all other current approaches. The IVN is an enabling technology but it is not the end objective of the business. The business is to establish a service business to allow sales entities to sell the services to end users.

To understand how the technology can be used one first also has to understand what role the CLEC is playing. To offer local services in the any Region, the CLEC provider has four options:

- *Reseller: This means that the company would buy from the I-LEC, the incumbent Local Exchange Carrier, at a discount and then would provide billing, sales, customer care and other factors. This means that with a 20% gross margin the company may at best have a 2-3% net profit margin if all goes well.*
- *Unbundled Elements Facilities Based: Use of Bell Atlantic's facilities, build some of its own. This means that the company may have a tandem switch in conjunction with the I-LEC providing local loop as well as local switching. This means that the carrier may have to do all that the reseller does plus has the tandem switch to add to the complexity. The switch allows for a slightly better gross margin since now the company uses a local loop at a fixed rate per month plus a rate per minute through the switch.*
- *Facilities Based: Use part of I-LEC facilities. This means that the company provides dial tone having a Class 5 type switch rather than just a tandem switch. It does not use the I-LEC switch and thus faces just a fixed fee per customer per month for the local loop and all other costs are in its own control. This is the strategy that maximizes gross margin, maximizes operating income margin, and minimizes cash flow requirements.*
- *Stand-alone: Build its own infrastructure, including switches, fiber, and wire to each subscriber. This is what such companies as Winstar, AT&T, MFS, and TCG are attempting to do. This way one gets around the local loop and thus hopefully gets a better margin. The problem with this extreme is the cost per customer in up-front capital. The loop, be it wire or wireless is \$500 to \$1,200 per subscriber. This is excessive and has a long term payback with limited interest in financing, especially for start up companies.*

We shall consider these alternatives latter in this paper as we develop a more detailed financial model for this business.

### **1.3 Architectural Positioning**

The positioning of these alternatives is shown below. The diagram shows capital intensiveness with profit margins. The provider has decided to be a facilities based player. TCG and MFS are Stand Alone players requiring significant capital resources. AT&T and MCI have entered as pure resellers although AT&T has considered through its wireless strategy to become a Stand Alone. WinStar is a Stand Alone via its 38 GHz license.

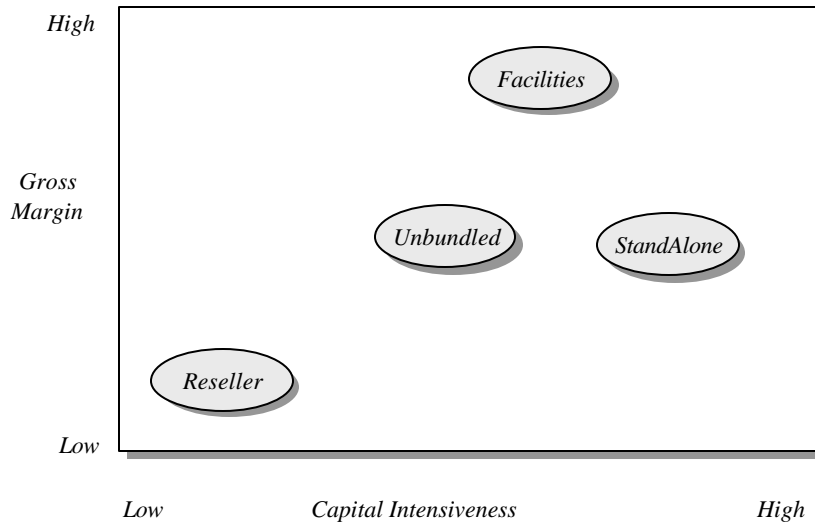

The provider network is shown below. It shows the provider switch and its interconnection to the I-LEC's local switching facilities. This strategy allows for use of the local loop from the I-LEC while bypassing the I-LEC switch and providing dial tone from the provider's switch.

### Standard Local Telephony

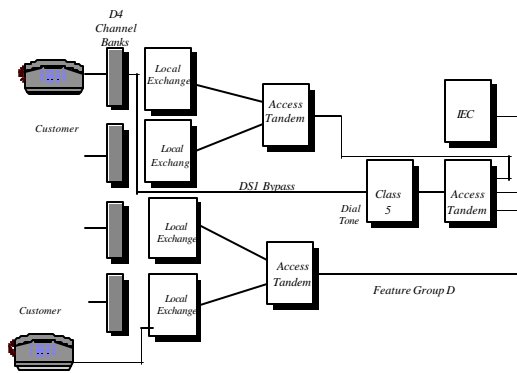

#### 1.4 The IVN

The basic system building block is the IP Voice Node (IVN), shown below:

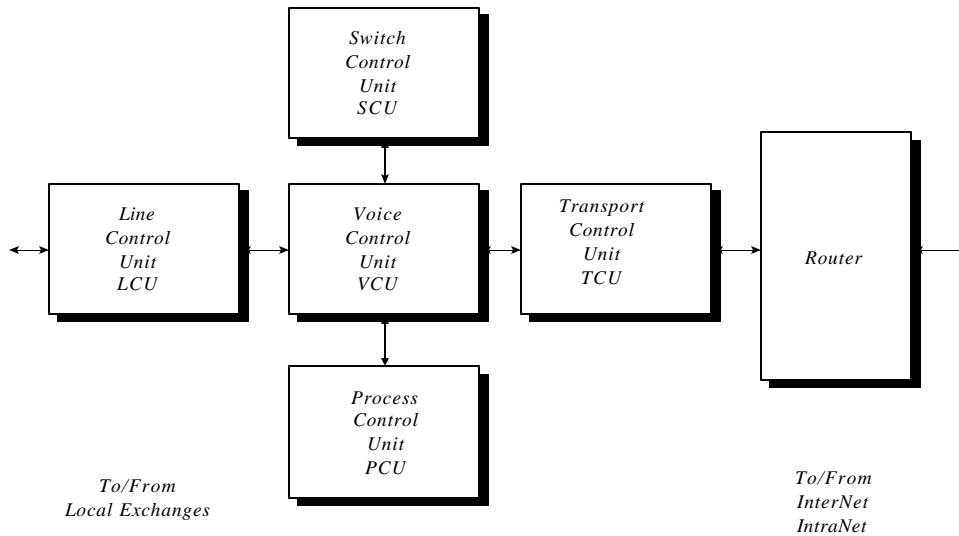

**LCU:** The Line Control Unit, LCU, is the interface between the telephone network and the IVN. The LCU provides for call initiation and termination. The initial LCU is a Dialogic card which provides for signaling to and from the local telephone network. The use of the Dialogic cards can be customized for each local market telephone interface elements.

**PCU:** Process Control Unit, PCU, provides the capability of controlling the processes of a general nature such as network management, billing, and the IVN provisioning capability. The PCU has an SNMP agent for network management and a billing control unit, BCU, for the management of calling cards and other similar elements.

**SCU:** The SCU, or switch control unit, provides for the conversion between the telephone number for dialing and the TCP/IP address for IP connectivity. On initiation, the IVN sends the SCU the telephone number to be called. The SCU converts the telephone number into an IP address and the SCU inserts this in the transmitted packet. On receive or termination the SCU converts the IP address and other header information into the terminating called number. The SCU sends this to the LCU which then connects this to the local exchange.

**VCU:** This is the IP Voice Processor or the voice card. The VCU compresses the analog voice signal into a digital signal. The current system converts the voice in an 8 Kbps signal. The provider believes that it can achieve a 4 Kbps compression in a year and a 2.4 Kbps compression in three years. This means that more subscribers can be supported on the same IP backbone network.

**TCU:** The Transport Control Unit, TCU, provides for the packet synchronization between transmit and receive. It is the scheduler of the packets on transmit and the synchronizer of the packets on receive. It also provides for the sorting out of the packets on transmit and receive. The TCU interfaces with the Router via an Ethernet interface.

**Router:** This is a standard router such as provided by Cisco and others.

The following figure depicts that implementation of an IP based system for LEC business. The following is assumed:

MDF, Main Distribution Frame: This is the physical connection wherein the local customer's copper line gets connected to an IVN located at the CO in a co-location chamber.

CO, Central Office: This is the central switching office of the I-LEC. It is never connected directly to the IP network.

SW, Switch: This is the CLEC's switch. Generally a switch is needed to connect to access tandems, the SS7 network, to do billing, to do other similar tasks. In a very general sense the switch is a very large file server for the IP network

RSW, Remote Switch: The RSW allows for remote SS7 and Access Tandem interfaces. The Access Tandem, AT, is the I-LECs concentrator switch which in turn connects to the local switches in a hierarchical fashion.

RSM, Remote Switch Module: The RSM provide for the remote provisioning of dial tone. It is a remote device that allows for dial tone and then also provides concentration. Namely it allocates a channel if an only if the access line is in use. Generally an access line is used at most 10% of the time so that 10 access lines may utilize an uncompressed voice channel. Remember that the IVN does at least 8:1 compression which is multiplicative to the 10:1 concentration.

IVN, IP Voice Node:

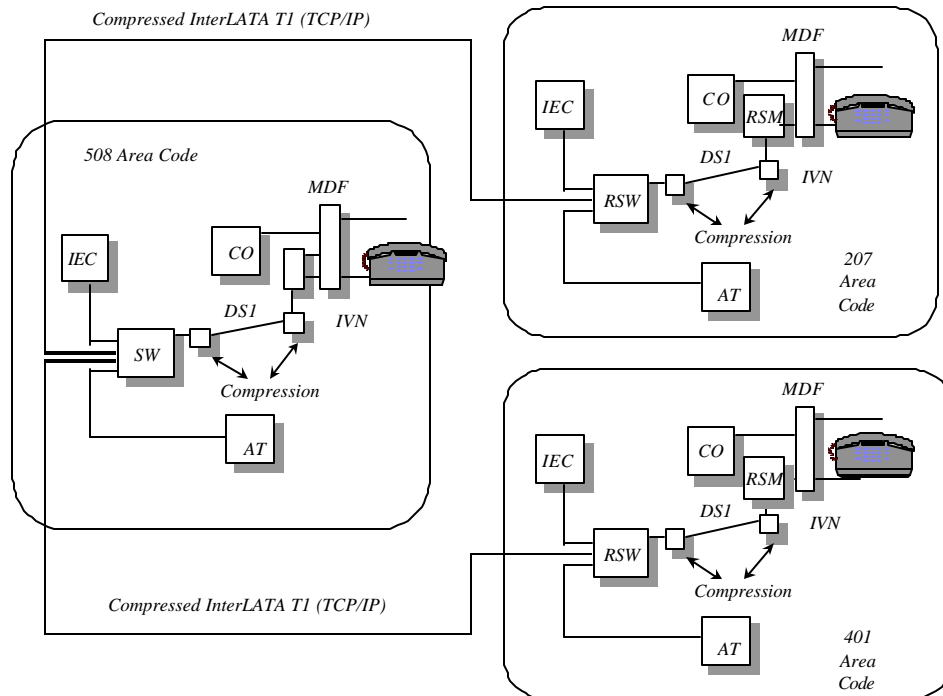

In this implementation, the provider can rapidly establish a facilities based system as follows:

- Use the regional hub shown in the 508 Area Code as the basic location for operations.
- Use remote switches, RS, that can be deployed at the 196 line multiple ratio rate with a bypass connection from a CO.

- *Connect between the CO and the RSW via the compressed and concentrated path. This means that with a 10% Erlang load one can achieve 240 users per T1 and with 8 bit compression one achieves 8 times that number or 1920 subscribers per T1. This means that the T1 costs can be made insignificant.*
- *Use the RSW for local interconnection to the Access Tandem.*
- *Use the RSW as the means to connect back to the main switch, the SW, via a compressed T1 using both speech compression and utilization compression. Use TCP/IP on that backbone to provide inter LATA service as a valued added carrier and not as an IEC. Thus the termination on any local AT can be done under the local access tariff.*

**2. ARCHITECTURE**

A key observation of this industry is that the computer types are not telco knowledgeable and the telco types are not computer literate. Thus most of the competitors do not recognize the overall differences. The IP is a packet network with control at the periphery and the signaling is in-band TCP/IP. This allows for great efficiencies in packet transport. The IEC network uses SS-7 out of band signaling and is structured for inefficient use of voice.

<i>Telephone LD</i>	<i>IP LD</i>
1. Uses "Class 4" Telco switching.	1. Uses a "Router" packet model in distributed network.
2. Uses SS7 "out of band signaling" requiring homogeneous network architecture.	2. Uses "in band" TCP/IP signaling allowing heterogeneous network flow.
3. Uses a circuit switched model.	3. Uses a packet switched network format.
4. Minimizes delay by circuit connection.	4. Minimizes delay via "router table assignment and minimal ISP flow.
5. Provides "toll grade" voice.	5. Provides "toll grade" voice with some network latency.
6. Requires significant software elements.	6. Allows open architecture for software support.
7. Provides low blocking probability.	7. Blocking can be minimized via Router control.
8. Is moderately scaleable.	8. Is completely scaleable.
9. Can leverage off of existing circuits from other carriers.	9. Generally uses common standards ad common facilities.

**2.1 Architectural Elements**

The following depicts the overall architecture for the implementation of a LEC IP telephony business. Consider the approach shown below. First the device is placed in a co-location chamber at the originating or terminating CO. This device is composed of an LAU, and IVN and a router. It is shown below.



## Architecture

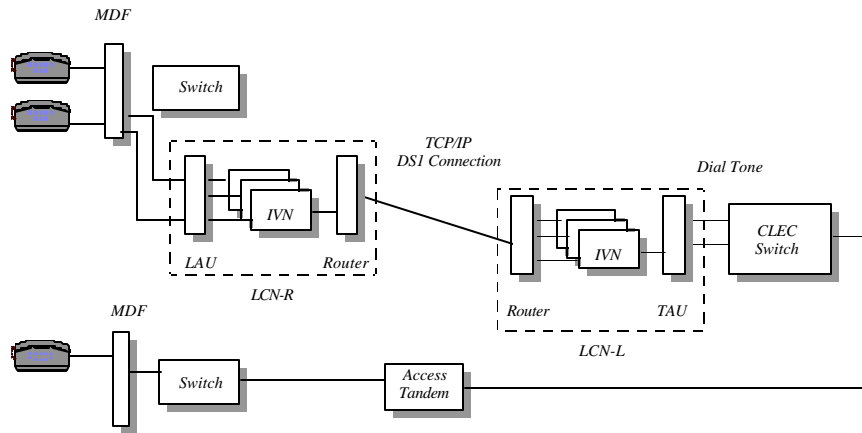

### 2.2 Subsystem Elements

The LAU is described below. It is merely a concentrator unit that connects an off hook line to the next available IVN port. The specific functionality is shown in the following.

### LAU Line Access Unit

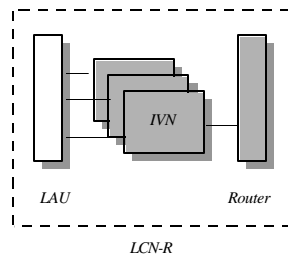

- *Functions on Call Request and Call Termination*
- *Call Request: From MDF cross connect, provides Dial tone, sets to receive calling tone, sends NNX to IVN to be sent to LCN-L at switch, connects a off-hook line to an available IVN port.*
- *Call Termination: From IVN, converts IP/NNX address to selected MDF line entry, connects to IVN and sends ringing tone to called party.*

The termination of a call is performed in a similar fashion. This is described below.

## TAU-Termination Access Unit

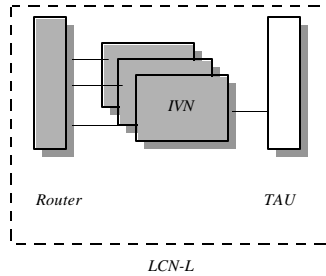

- Functions to terminate or initial call requests or call terminations.
- Call Request: For calls coming from LCN-R, and coming from IVN, takes IP/NNX and converts to line side Line Card Location to provide dial tone continuity, and completes call.
- Call Termination: For calls coming from CLEC switch, selects an idle IVN port and connects a trunk.

The entire Line Control Unit in the remote configuration and is shown below. This is what is placed in the remote Central Office.

## LCN-R; Line Control Node, Remote

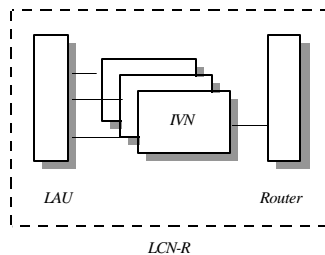

- Provides concentration on links to switch.
- LAU can provide concentration to the ratio of  $1/E$ , where  $E$  is the Erlang load per line.
- That is if there are 1200 users each at 0.1 Erlang, then there need only be 120 IVN access line ports.
- IVN further compresses 8:1 depending on codec, thus router is seeing 80:1 compression of lines.

The corresponding LCN for local operations is shown below.

## LCN-L; Line Control Node, Local

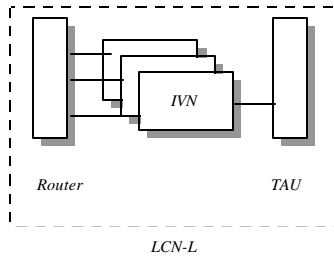

- The LCN-L is the local decompressor of the signals.
- The LCN-L provides for Line or Trunk connections at the remote switch.

The total network layout is shown in the following figure. The LA does 10:0 concentration, the IVN does 8:1 compression so that 80:1 utilization is provided between the remote and local system. This means that a T1 which may span 100 miles at \$2,400 per month will carry 24 time 80 access lines, or be cost-ed out at \$0.125 per month per access line.

## Network Architecture

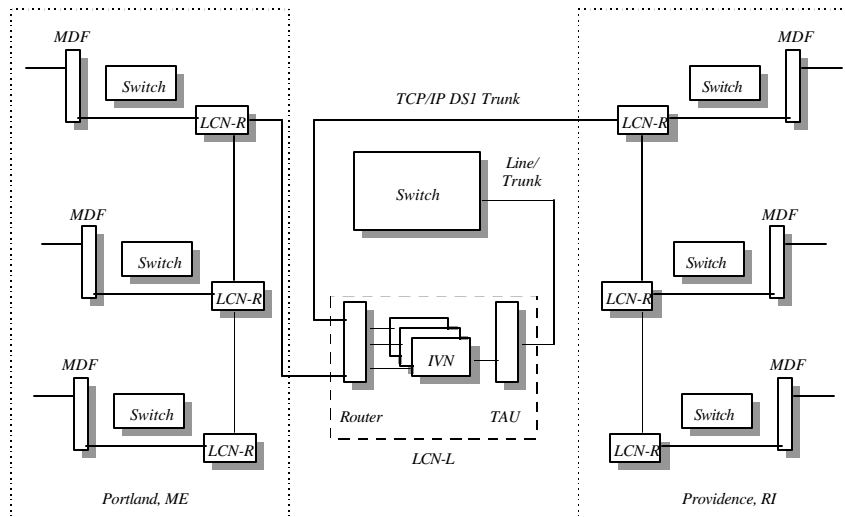

### 3. ECONOMICS

The basic economics of the CLEC business are as follows:

- *The provider will focus on residential and small/medium business customers that are in the “doughnut” and not the “whole”, namely the provider will focus on those customers who are in a ring around the major market, for example, in Massachusetts, between Routes 128 and Routes 495.*
- *The provider will through its own switch offer Custom Calling services as well as basic calling features at a price point that is 10% to 20% lower than the I-LEC rates. Thus a customer using \$30 per month in current calling will pay \$24 per month.*
- *The provider will bundle long distance, Custom Calling and other Services.*
- *The provider will sell Custom Calling services, typically three per customer, at 20% less than current rates averaging \$3.00 per month thus adding another \$7.20 per month on the average bill resulting in a \$31.20 per month per residential services. The provider also provides its own voice mail platform for both the reseller and facilities based elements of the business.*
- *The provider will pay on a per access line basis \$9 per month per access line to the ILEC. It is assumed that there are 1,200 minutes per month per access line so that this is approximately \$0.0100 per minute.*
- *The provider will target Central Offices such that the provider will connect a T1 carrier from the targeted CO to its switch. The T1 will cost \$325 per month. Assuming a 50% loading, and an Erlang load of 10% per customer per month, this means that a T1 can handle 120 customers per month, or approximately \$3.00 per month per customer. Greater loading is possible and that will reduce the cost. This is approximately \$0.0025 per minute.*
- *The switch that the provider has is leased at approximately \$8,000 per month. The switch can handle 10,000 access lines at that rate. That is \$0.80 per access line per month or \$0.0070 per minute per access line. At 50% loading this is \$1.60 per access line or \$0.0140 per minute.*
- *The sales costs are approximately 15% of the gross revenue. This is \$5.00 per month per access line or approximately \$0.0020 per minute.*
- *The operations costs are the combined leased costs of the operations support systems of \$0.080 per access line or \$0.0070 per minute. In addition the billing is \$2.40 per bill per month per access line or \$0.0020 per minute.*

The net margin is shown below. Assuming no additional revenue from IEC services or any other services, this is a 10% net margin on a 20% discount. If the discount is less than 20%, then the difference basically goes to the bottom line. The following Table depicts the differences in the pure reseller market and the facilities based market.

### **3.1 Operating Economics**

The facilities based market is shown as in the above. In addition the Reseller approach is also shown. In the reseller approach, however, the rate reduction is 5% rather than 20%, the dominant costs factor is the cost of service which is 81% of the Gross ILEC Revenue, and one still has to deal with billing and operations as fixed costs.

McGarty: The Application of IP Telephony to Local Exchange Carriers

Element	Facilities Based			Reseller		
	Per Access Line	Per Minute	Percent	Per Access Line	Per Minute	Percent
ILEC Revenue	\$39.00	\$0.0325	125.00%	\$39.00	\$0.0325	105.26%
Revenue	\$31.20	\$0.0260	100.00%	\$37.05	\$0.0309	100.00%
Local Loop	\$12.00	\$0.0100	38.46%	\$0.00	\$0.0000	0.00%
Transport	\$4.00	\$0.0033	12.82%	\$0.00	\$0.0000	0.00%
Switch	\$1.60	\$0.0013	5.13%	\$0.00	\$0.0000	0.00%
Operations Support	\$0.80	\$0.0007	2.56%	\$0.80	\$0.0007	2.16%
Billing	\$2.40	\$0.0020	7.69%	\$2.40	\$0.0020	6.48%
Service	\$0.00	\$0.0000	0.00%	\$31.59	\$0.0263	85.26%
Net Operating Expense	\$20.80	\$0.0173	66.67%	\$34.79	\$0.0290	93.90%
Gross Margin	\$10.40	\$0.0087	33.33%	\$2.26	\$0.0019	6.10%
Cost of Sales	\$6.24	\$0.0052	20.00%	\$7.41	\$0.0062	20.00%
G&A	\$2.40	\$0.0020	7.69%	\$2.40	\$0.0020	6.48%
Net Expenses	\$29.44	\$0.0245	94.36%	\$44.60	\$0.0372	120.38%
Net Margin	\$1.76	\$0.0015	5.64%	(\$7.55)	(\$0.0063)	-20.38%

The following Table is the same comparison but now for a 3,000 per minute business line.

Element	Facilities Based			Reseller		
	Per Access Line	Per Minute	Percent	Per Access Line	Per Minute	Percent
ILEC Revenue	\$100.00	\$0.0333	125.00%	\$100.00	\$0.0333	105.26%
Revenue	\$80.00	\$0.0267	100.00%	\$95.00	\$0.0317	100.00%
Local Loop	\$12.00	\$0.0040	15.00%	\$0.00	\$0.0000	0.00%
Transport	\$4.00	\$0.0013	5.00%	\$0.00	\$0.0000	0.00%
Switch	\$1.60	\$0.0005	2.00%	\$0.00	\$0.0000	0.00%
Operations Support	\$0.80	\$0.0003	1.00%	\$0.80	\$0.0003	0.84%
Billing	\$2.40	\$0.0008	3.00%	\$2.40	\$0.0008	2.53%
Service	\$0.00	\$0.0000	0.00%	\$81.00	\$0.0270	85.26%
Net Operating Expense	\$20.80	\$0.0069	26.00%	\$84.20	\$0.0281	88.63%
Gross Margin	\$59.20	\$0.0197	74.00%	\$10.80	\$0.0036	11.37%
Cost of Sales	\$16.00	\$0.0053	20.00%	\$7.60	\$0.0025	8.00%
G&A	\$2.40	\$0.0008	3.00%	\$2.40	\$0.0008	2.53%
Net Expenses	\$39.20	\$0.0131	49.00%	\$94.20	\$0.0314	99.16%
Net Margin	\$40.80	\$0.0136	51.00%	\$0.80	\$0.0003	0.84%

### 3.2 Tradeoff Analysis

We can now do the same analysis for a comparison of three options: a fiber based system using a dedicated fiber to a co-location chamber in a central office, a concentrator using a remote switch module, RSM, and a concentrated leased T1 one, and finally the IP based solution. We do this analysis for both the local service as well as the long distance service. The final metric for comparison is the effective cost per minute.

<i>Cost Element</i>	<b>Local Service</b>			<b>LD Service</b>		
	<i>Fiber Based</i>	<i>RSM Based</i>	<i>IP Based</i>	<i>Fiber Based</i>	<i>RSM Based</i>	<i>IP Based</i>
Co-Location Space Lease per Month	\$500	\$500	\$500	\$500	\$500	\$500
Fiber Cost per Mile	\$150,000	\$150,000	\$150,000	\$150,000	\$150,000	\$150,000
Miles to CO	4	0		75		
Fiber Cost	\$600,000	\$0	\$0	\$11,250,000	\$0	\$0
Fiber Cost per Month	\$12,000	\$0	\$0	\$225,000	\$0	\$0
Number Effective T1s per Fiber	\$360	\$360	\$360	\$360	\$360	\$360
Effective Fiber Loading	5%	5%	5%	20%	20%	20%
Monthly Fiber T1 Costs	\$667	\$0	\$0	\$3,125	\$0	\$0
Switch Line Card Cost/Line	\$150	\$150	\$150	\$150	\$150	\$150
RSM Cost per Line		\$50	\$50		\$50	\$50
Lease Rate Line Card per Month	\$3	\$4	\$4	\$3	\$4	\$4
Mux Costs per T1 Bank	\$125	\$125	\$125	\$125	\$125	\$125
Mux Cost per Month	\$3	\$3	\$3	\$3	\$3	\$3
T1 Costs per Month		\$250	\$250		\$2,250	\$2,250
IPN Capital Costs per T1 Unit	\$0		\$20,000			\$20,000
Monthly IPN Costs	\$0	\$0	\$400	\$0	\$0	\$400
RSM Concentration Ratio	1	10	10	1	10	10
IPN Compression Ratio	1	1	8	1	1	8
Number of AL per T1	1	10	80	1	10	80
Total Costs per Month per T1	\$672	\$257	\$657	\$3,131	\$2,257	\$2,657
Number of Minutes per AL per Month	1,200	1,200	1,200	1,200	1,200	1,200
Total Minutes per month per T1	28,800	288,000	2,304,000	28,800	288,000	2,304,000
Effective Cost per Minute	\$0.0233	\$0.0009	\$0.0003	\$0.1087	\$0.0078	\$0.0012

The bottom line is as follows:

**Fiber Based System:** This has a local cost per minute of \$0.0233 and an LD cost of \$0.1087. We have used 5% loading for local and 20% loading for LD.

**RSM Based Design:** This assumes that the RSM has a local switch module in the co-location site plus uses 10:1 concentration. The local costs is \$0.0009 and the LD is \$0.0078. This is a dramatic difference. It says that putting a concentrator reduces the costs about 10:1 for the local as expected and much more so for the LD costs.

**IP Based:** This is the most efficient. It has the lowest local costs and the lowest, and almost inconsequential costs for long distance.

The conclusion drawn from this is that IP telephony will drive all costs down to a minimal costs base. This is why AT&T has recently announced the elimination of circuit switches in their domestic network, the use by Level 3 and Qwest of IP backbone, the AT&T and BT JV for international IP and the Bell Atlantic IP services. IP will change dramatically the costs of service and will drive up usage and down costs.

#### 4. REGULATORY

The Telecommunications Act of 1996 recently passed by Congress removed many of the restrictions that had rendered cable television, long-distance telephony and local telephony services as separate and, with the exception of long distance, quasi-monopolistic businesses. The Act allows service providers in each of those industries the opportunity to compete in the others, provided the service provider opens its facilities for competitive access. In so doing, the market is opened to other companies, which encourages competition, innovation, better pricing and the integration of communications technologies and services.

The Act requires local telephone companies like Bell Atlantic (also called incumbent local exchange companies, or ILECs) to provide CLECs like COMAV with nondiscriminatory access and interconnection to all of its public switched telephone network (PSTN) facilities. Most of the provisions of the Act are to be implemented in 1997, including forcing local telephone companies to offer a new set of wholesale carrier tariffs just for its new competitors. The three most important new tariff issues are:

- *Wholesale price discounts* from the ILEC (Bell Atlantic) retail tariff for a straight resell of the ILEC service by the CLEC to the end user (herein referred to as the “reseller approach”); and
- *Cost-based tariff rates* for public network interconnection and access to a comprehensive set of “unbundled” or individual public network elements, features and functions which may be combined with facilities owned and/or operated by the CLEC (herein referred to as the “unbundled approach”).
- *The Unbundled Approach:* The Department of Public Utilities in Massachusetts, DPU, for example, has ruled on wholesale rates pursuant to the Act. Unbundled prices remain at \$9.00 for each subscriber loop (which is the wire that connects right to the subscriber’s home/office. The Federal Communications Commission (FCC) has recommended much lower average price of \$8.00 per month. (Average prices set a single price for both rural and urban areas). Major CLECs like AT&T and MCI have requested arbitration to force Bell Atlantic to set interim cost-based rates. A DPU decision is expected soon. According to the rules requiring nondiscriminatory rates, any CLEC is allowed to avail itself of the same wholesale tariff rates as any other CLEC, no matter the size or bargaining power. In late November, the DPU stated that it would set permanent deaveraged rates, that is, separate rates for rural and urban areas. It is anticipated that the current high charges will come down in urban areas substantially.

#### 4.1 The 96’ Telecommunications Act

The Telecommunications Act of 1996 has provide for the open competition in the Local Exchange Carrier markets. There are several factors that make this new competitive environment dramatically different from that of the Inter Exchange Carrier markets in which AT&T and MCI and others found themselves in 1984. Specifically, there is a technological change wherein the issue of economic scale has been eliminated, namely there are de minimis entry barriers from an economic perspective. The barrier to entry is the issue of Interconnection, which simply stated is the need to connect from one new LEC entrant to the existing monopoly LEC player, specifically the RBOC. Thus there exist many new and significant legal issues relating to the implementation of such fair and equitable interconnection. The FCC in its role as Administrative Agency has taken steps effective August 8, 1996 to promulgate rules of behavior.<sup>2</sup> The alternatives

---

<sup>2</sup>See FCC First Report and Order on the Implementation of the Local Competition Provisions in the Telecommunications Act of 1996. These relate expressly to Sections 251 and 252 of the Act.

available if such rule fail to provide for a competitive framework are the antitrust laws. This new area for antitrust law is one that rejoins many of the issues that were thought to be left behind at the time of the AT&T divestiture.

The Act as amended in 1996 has removed antitrust protection from the telecommunications industry.<sup>3</sup> In light of that fact, it is necessary to reexamine the implications of the many arrangements that have been customary practice, and view those arrangements in the light that all other similar arrangements can be viewed in all other industries. From an historical perspective, the Antitrust laws have been used to manage the gross misconduct of larger entities in existing competitive markets. In the case of local exchange telecommunications, however, there is a sharp distinction. Namely, the existing entities are the only player in the market and thus have essentially full monopoly control. The 1996 Act in Sections 251 and Sections 252 provide a vehicle that allows new entrants into the market so that a competitive environment may evolve. The issues however focus around the approaches taken in the new Act and how they may be interpreted.

There seems to be no question but that Congress had the intent to create competition in the Local Exchange markets. The wording of the Act and its reflection in the Commission's attempt to clarify certain issues leads directly to that belief. However, it has been seen that the Incumbent LECs, namely the RBOCs, have a strong and vested interest in delaying or prolonging that effort. The track record of companies such as Bell Atlantic are clear in their continued attempts to delay the entry of companies such as MFS and Teleprompt ,especially through the process of state regulatory delay. The Commission has the sets of certain authorities in the new Act to facilitate this process and create a more competitive environment but the States retain certain controls and interests.

Furthermore, telecommunications has, as a result of the Act, become potentially a more competitive environment. Despite the intention to allow competition, the industry also has certain existing structures and interlocking relationships that permit the incumbents to retain significant share by blocking the entrance of new players. This paper focuses on the local exchange market in which the local exchange carrier, "LEC", is the principal player. Twelve years ago the interexchange market was opened up to full competition. The result is an network that allows for strong competition with even stronger competitors. The local exchange market is closed. This paper provides an overview framework for this market, the technological change agents that make it dramatically different from other markets, and the re-application of antitrust law from the perspective of maximizing the public welfare, independent of the individual competitors.

The Telecommunications Act of 1996 removed antitrust protection from the telecommunications industry. In light of that fact, it is necessary to reexamine the implications of the many arrangements that have been customary practice, and view those arrangements in the light that all other similar arrangements can be viewed in all other industries. From an historical perspective, the Antitrust laws have been used to manage the gross misconduct of larger entities in existing competitive markets. In the case of local exchange telecommunications, however, there is a sharp distinction. Namely, the existing entities are the only player in the market and thus have essentially full monopoly control. The 1996 Act in Sections 251 and Sections 252 provide a vehicle that allows new entrants into the market so that a competitive environment may evolve. The issues however focus around the approaches taken in the new Act and how they may be interpreted.<sup>4</sup>

There seems to be no question but that Congress had the intent to create competition in the Local Exchange markets. The wording of the Act and its reflection in the Commission's attempt to clarify certain issues leads directly to that belief. However, it has been seen that the Incumbent LECs, namely the RBOCs, have a strong and vested interest in delaying or prolonging that effort. The track record of companies such as Bell Atlantic are clear in their continued attempts to delay the entry of companies such as MFS and Teleport ,especially

---

<sup>3</sup>See Section 601 of the Act.

<sup>4</sup>The FCC has issue a Notice of Public Rulemaking ("NPRM") CC 96-98 which focuses on the implementation via the Sections 251 and 252 of the Act.



through the process of state regulatory delay. The Commission has the sets of certain authorities in the new Act to facilitate this process and create a more competitive environment but the States retain certain controls and interests.

There are several significant changes that are also occurring in the delivery of these types of products that will allow for the dramatic entry of new competitors. These will also be explored. Specifically, technology allows for disaggregation of functions in the delivery of the product. Technology also allows these functions or product elements to be delivered at marginal prices since the inherent scale in the industry is disappearing. Namely the scale economies of copper wire and large switches is now being replaced by the scale-less technology of wireless and ATM or frame relay switching.

#### **4.2 US Administrative Code 47**

The implementation of the 1996 Act is done in the Code of Federal Regulations (“CFR”), the US Code, expressly Title 47. The regulation process in the US is a several fold process. First the law reflects the demands of Congress and the approval of the President. Thus the law is the underlying document. Then the FCC, or any other administrative body, interprets the law in terms of the Federal Regulation, which is the operative document. One can reflect on the Law but one must rely on the CFR. It is this final document that reflects the governments position and how industry must operate.

To go from law to a regulation the FCC, as does most other federal agencies, goes first to a Notice of Public Rule Making (“NPRM”) and then to a Report and Order (“R&O”). The R&O then has attached to it the modifications to the CFR. This is what has happened in the 1996 Act. The Act became law on February 8, 1996, and the new CFR rules became effective on August 8, 1996. The latter are the controlling documents.

The new CFRs regarding the interconnection issue will be the most significant ones in this business of IP voice.

#### **4.3 Philosophical Implications**

The issues of political philosophy may seem a far cry from IP voice but it is clearly in the middle of it. Any process which provides a service which the government is in the middle of will perforce have a political element and in turn an overriding political philosophy. We consider two philosophies and their implications.

The first is the Rawls philosophy of John Rawls. His philosophy has three elements. The first is his concept of an Original Position. The Original Position is that all governments are based on a “contract” between its citizens and that the ideal contract is one developed in a consensus between all its citizens that allow it and them to agreement on principles of government. This is like Rousseau and the Social Contract. It is a contract amongst and between the citizens and the government, one and indistinguishable. From this follows the two Rawls principles of justice; First Principle, each persons shall have equal rights to the most extensive total system of equal basic liberties with a similar system of liberty for all, and Second Principle, social and economic inequalities are to be arranged so that they both, (I) provide the greatest benefit to the least advantaged, and (ii) attached to offices and positions open to all under conditions of fair equality of opportunity.<sup>5</sup>

One may say what does this have to do with the IP. Simply stated this philosophy controls access prices and who “must have” access. As to access prices, this is reflected in the Baumol Willig theorem of access pricing. They have used the concept of Ramsey pricing, also know as second best pricing. This is a sub-optimal version of Pareto pricing. Pareto pricing is a pricing mechanism in the market whereby any change in one person to increase their welfare will not diminish the welfare of any other person. Thus something is Pareto optimal if I give you one more candy bar, that increase your welfare or happiness, and that their result

---

<sup>5</sup>See Kukathas, Rawls, Stanford University Press.

of doing so does not upset anyone else. Hardly a reasonable assumption but a key basis of economic. The Ramsey scheme tries to balance welfare and profit.

The Baumol Willig theorem states that we want to maximize the welfare of the populace while keeping the profits of the monopolies high. This is a classical example of an ad hoc propiter hoc theorem. Clearly the result is that we tax the people and subsidize the monopoly.

The other issue is how do we measure welfare. If we are a Rawlsian then we measure welfare as the welfare of the least of us and not the average welfare. Rawls states that if we maximize average welfare then we disadvantage the least of us and this is not just. Thus as a Rawlsian we demand Universal Service. We must insist that all people have access to all service elements, whether it makes economic senses or not, we do so via wealth transfer.

Hopefully, this political theory should now not seem too foreign. Rawlsians favor the implementation of access fees and the implementation of Universal Service. Indeed, the true Rawlsian would impute Universal Service to even computer terminals as has been stated by Vice President Gore.

In contrast is the classic liberal, now called libertarian view. It is more a combination of minimal government involvement and maximizing utility to the consumer. This is the philosophy of the utilitarian. Here we assume that government has a de minimis role and that the market follows of its own accord and that the market, in an Adam Smith fashion, will clear any inefficiencies of distribution and pricing mechanisms. It assumes that each business should stand on its own stead and that utility is maximized on average. The result from the libertarian school, as opposed to the contractarians or Rawlsians, is the elimination of access fees and the elimination of universal Service.

It will be important to recognize that these political philosophies dominate the overall play of regulation in all markets. These two schools of thoughts, the libertarians versus the contractarians, whether they know they are one or not, will have a great deal to do with our development as an industry.

## **5. CONCLUSIONS**

There is a significant future for IP Voice and companies such as in the CLEC market. Where the ultimate success will be is still uncertain. However, the challenges will continue to be regulatory and not technical. We see voice modems and codecs reducing the delay to less than 40 msec and that access to the High Speed backbone will reduce transport packet delay to a similar numbers. Voice quality will have low delay and high recognizability. Access to IP voice will also be a much simpler with IVN architectures. Finally, pricing will make this highly costs competitive to the existing alternatives, however the major conclusion is that the IP architecture enables multimedia communications via TCP/IP more than SS7 will ever be able to do. TCP/IP is a "natural" effect of integrating voice and data. The existing Telco architecture is archaic and will not survive. The author presented this case in 1990 at Harvard and the only conclusion is that it is even more so now than it was then.

## **6. REFERENCES**

1. Baumol and Sidak, Toward Competition in Local Telephony, MIT Press (Cambridge, MA), 1994.
2. Coll, S. The Deal of the Century, Atheneum (New York), 1986.
3. de Sola Pool, I., Technologies Without Barriers, Harvard University Press (Cambridge, MA), 1990.
4. de Sola Pool, I., The Social Impact of the Telephone, MIT Press (Cambridge, MA), 1977.
5. Habermas, J., Between Facts and Norms, MIT Press (Cambridge, MA), 1996.
6. Kahn, A.E., The Economics of Regulation, MIT Press (Cambridge, MA), 1989.
7. Kukathas, C., P. Pettit, Rawls, Stanford University Press (Stanford, CA), 1990.

8. McGarty, T.P., G.J. Clancey, Cable Based Metro Area Networks, IEEE Jour on Sel Areas in Comm, Vol 1, No 5, pp 816-831, Nov 1983.
9. McGarty, T.P., Alternative Networking Architectures; Pricing, Policy, and Competition, Information Infrastructures for the 1990s, John F. Kennedy School of Government, Harvard University, November, 1990.
10. McGarty, T.P., Information Architectures and Infrastructures; Value Creation and Transfer, Nineteenth Annual Telecommunications Research Conference, Plenary Address and Paper, Solomon's Island, September, 1991.
11. McGarty, T.P., Alternative Networking Architectures, B. Kahin Editor, McGraw-Hill (New York), October, 1991.
12. McGarty, T.P., Communications Networks; A Morphological and Taxonomical Approach, Private Networks and Public Policy Conference, Columbia University, New York, October, 1991.
13. McGarty, T.P., Wireless Communications Economics, Advanced Telecommunications Institute Policy Paper, Carnegie Mellon University, February, 1992.
14. McGarty, T.P., Communications Network Morphological and Taxonomical Policy Implications, Telecommunications Policy Research Conference, Solomon's Island, MD, September, 1992.
15. McGarty, T.P., Architectures et Structures de L'Information, Reseaux, No 56, pp. 119-156, December, 1992, Paris.
16. McGarty, T.P., Economic Structural Analysis of Wireless Communications Systems, Advanced Telecommunications Institute Policy Paper, Carnegie Mellon University, February, 1993.
17. McGarty, T.P., Spectrum Allocation Alternatives; Industrial; Policy versus Fiscal Policy, MIT Universal Personal Communications Symposium, March, 1993.
18. McGarty, T.P., Wireless Access to the Local Loop, MIT Universal Personal Communications Symposium, March, 1993.
19. McGarty, T.P., Access to the Local Loop; Options, Evolution and Policy Implications, Kennedy School of Government, Harvard University, Infrastructures in Massachusetts, March, 1993.
20. McGarty, T.P., IP Architectural and Policy Implications, Kennedy School of Government, Harvard University, Public Access to the IP, May 26, 1993.
21. McGarty, T.P., Access Policy and the Changing Telecommunications Infrastructures, Telecommunications Policy Research Conference, Solomon's Island, MD, September, 1993.
22. McGarty, T.P., Wireless Architectural Alternatives: Current Economic Valuations versus Broadband Options, The Gilder Conjectures; Solomon's Island, MD, September, 1994
23. McGarty, T.P., From High End User to New User: A New IP Paradigm, McGraw Hill (New York), 1995.
24. McGarty, T.P. , "Disaggregation of Telecommunications", Presented at Columbia University CITI Conference on The Impact of Cybercommunications on Telecommunications, March 8, 1996.
25. Posner, R.A., Economic Analysis of :Law, Little Brown and Co. (Boston, MA), 1992.
26. Posner, R.A., The Problems of Jurisprudence, Harvard University Press (Cambridge, MA), 1990.
27. Posner, R.A. Overcoming Law, Harvard University Press (Cambridge, MA), 1995.
28. Posner, R.A., Antitrust Law, University of Chicago Press (Chicago, IL), 1976.
29. Posner, R.A., The Economics of Justice, Harvard University Press (Cambridge, MA), 1983.
30. Rawls, J., A Theory of Justice, Harvard University Press (Cambridge, MA), 1971.
31. Rawls, J., Political Liberalism, Columbia University Press (New York), 1996.
32. Spulber, D.F., Regulation and Markets, MIT Press (Cambridge, MA),1990.